

ATTACHMENT C

MEASUREMENT DEVICE DOCUMENTATION

- C.1 Wintu Pump Station and Well Meter Testing Results**
- C.2 Meter Warranty Documents**
- C.3 Meter Product Data Sheets**
- C.4 How to Read Your Meter**
- C.5 Standard Operating Procedure for Replacement Meter Testing**

ATTACHMENT C.1

Wintu Pump Station and Well Meter Testing Results

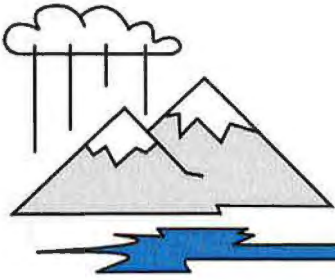

DIRECTORS
TED BAMBINO BOB NASH
JIM SMITH JEFF O. STEPPAT
LEIMONE WAITE

DAVID J. COXEY
Secretary/Treasurer/General Manager

BELLA VISTA WATER DISTRICT

11368 E. STILLWATER WAY • REDDING, CALIFORNIA 96003-9510
TELEPHONE (530) 241-1085 • FAX (530) 241-8354

May 30, 2017

Don Bader, Area Manager
U.S. Bureau of Reclamation
Northern California Area Office
16349 Shasta Dam Blvd.
Shasta Lake, CA 96019-8400

Re: Meter Used to Measure Bureau Supplied Water for Payment

Dear Mr. Bader:

The following is the information being provided:

1. Location: Wintu Pump Plant
580 Hilltop Drive, Redding, CA 96003
2. Manufacturers:

Recorder	GE Fanuc
Flow Transmitter	Fischer-Rosemount – Model No. 3051S1CD1A2E12A1AM5TC1 Low Flow Serial #0297339 High Flow Serial #0298086
3. Model number of recorder: GE 90/30 PLC CPU 374
4. Measurement scale: Recording - 120 cfs = 100%, Totalizer
5. Method used to compute Federal water in acre feet: Direct Read
6. Date installed: Recorder – March 2006; Transmitters – March 2008
7. (a) Date of last testing: March 28, 2017
(b) Meter Tester: Randy Olsen, BVWD Electrical/Instrumentation Technician

We are an equal opportunity employer and provider.

Mr. Bader
May 30, 2017
Page Two

8. Description of maintenance schedule: daily visual inspection, cleaning when necessary, lubrication and calibration annually.

9. Who reads the meter: District water treatment operators: Will Markword, Mark Maty, Joe Pedersen, Brad Solso, Tom Zaharris and Electrician, Randy Olsen.

Attached is a copy of the Flow Meter Verification record sheet. If you require further information, please contact me at (530) 241-1085 ext. 114.

Sincerely,

A handwritten signature in blue ink, appearing to read "Don M. Groundwater".

Don M. Groundwater, PE
District Engineer

Enclosure

WINTU PUMP STATION
VENTURI DP FLOW METER VERIFICATION

DATE OF VERIFICATION: 3-28-17

Listed below are the milliamp, transmitter water column readings and the calculated CFS. The first line is the BIF factory settings the HAND written entry is the actual field readings during verification.

bart
 5.60 Low
 3.19 High

Low Range Transmitter	14.820 mA	2"	12.92 CFS
CTP - 4 2" WC	4.35 <u>15.33</u> mA	"	

High Range Transmitter	5.722mA	2"	12.92 CFS
CTP - 4 2" WC	5.92 <u>8.0</u> 9.41 mA	"	

Low Range Transmitter	19.302mA	4"	18.27 CFS
CTP - 3 4" WC	4.75 <u>19.4</u> mA	"	

High Range Transmitter	6.436 mA	4"	18.27 CFS
CTP - 3 4" WC	9.59 <u>6.48</u> mA	"	

High Range Transmitter	7.851mA	10"	28.88 CFS
CTP - 2 10" WC	<u>7.85</u> mA	"	

High Range Transmitter	20.000mA	172.61"	120 CFS
CTP - 1 172.61" WC	<u>19.96</u> mA	"	

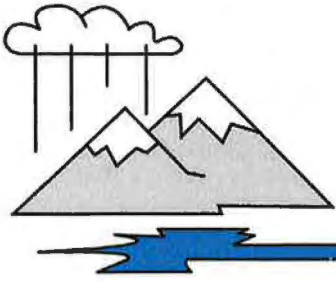

DIRECTORS
TED BAMBINO BOB NASH
JIM SMITH LEIMONE WAITE
FRANK SCHABARUM

DAVID J. COXEY
Secretary/Treasurer/General Manager

BELLA VISTA WATER DISTRICT

11368 E. STILLWATER WAY • REDDING, CALIFORNIA 96003-9510
TELEPHONE (530) 241-1085 • FAX (530) 241-8354

July 9, 2018

Don Bader, Area Manager
U.S. Bureau of Reclamation
Northern California Area Office
16349 Shasta Dam Blvd.
Shasta Lake, CA 96019-8400

Re: Meter Used to Measure Bureau Supplied Water for Payment

Dear Mr. Bader:

The following is the information being provided:

1. Location: Wintu Pump Plant
580 Hilltop Drive, Redding, CA 96003
2. Manufacturers:

Recorder	GE Fanuc
Flow Transmitter	Fischer-Rosemount – Model No. 3051S1CD1A2E12A1AM5TC1 Low Flow Serial #0297339 High Flow Serial #0298086
3. Model number of recorder: GE 90/30 PLC CPU 374
4. Measurement scale: Recording - 120 cfs = 100%, Totalizer
5. Method used to compute Federal water in acre feet: Direct Read
6. Date installed: Recorder – March 2006; Transmitters – March 2008
7. (a) Date of last testing: February 14, 2018
(b) Meter Tester: Randy Olsen, BVWD Electrical/Instrumentation Technician

We are an equal opportunity employer and provider.

Mr. Bader
July 9, 2018
Page 2

8. Description of maintenance schedule: daily visual inspection, cleaning when necessary, lubrication and calibration annually.
9. Who reads the meter: District water treatment operators: Will Markword, Mark Maty, Joe Pedersen, Brad Solso, Tom Zaharris and Electrician, Randy Olsen.

Attached is a copy of the Flow Meter Verification record sheet. If you require further information, please contact me at (530) 241-1085 ext. 112.

Sincerely,

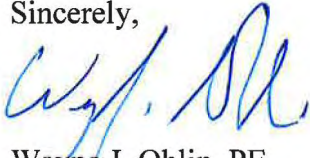

Wayne J. Ohlin, PE
District Engineer

Enclosure

WINTU PUMP STATION
VENTURI DP FLOW METER VERIFICATION

DATE OF VERIFICATION: 2-17-18

Listed below are the milliamp, transmitter water column readings and the calculated CFS. The first line is the BIF factory settings the HAND written entry is the actual field readings during verification.

Low Range Transmitter	14.820 mA	2"	12.92 CFS
CTP - 4 2" WC	<u>15.07</u> mA	<u>2.04</u> "	

High Range Transmitter	5.722mA	2"	12.92 CFS
CTP - 4 2" WC	<u>5.72</u> mA	<u>2.04</u> "	

Low Range Transmitter	19.302mA	4"	18.27 CFS
CTP - 3 4" WC	<u>19.39</u> mA	<u>4</u> "	

High Range Transmitter	6.436 mA	4"	18.27 CFS
CTP - 3 4" WC	<u>6.42</u> mA	<u>4</u> "	

High Range Transmitter	7.851mA	10"	28.88 CFS
CTP - 2 10" WC	<u>7.85</u> mA	<u>10</u> "	

High Range Transmitter	20.000mA	172.61"	120 CFS
CTP - 1 172.61" WC	<u>19.99</u> mA	<u>171.71</u> "	

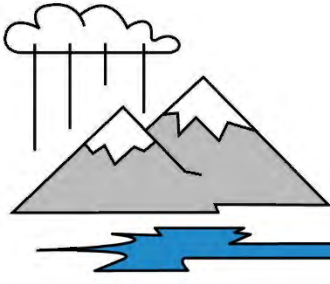

DIRECTORS
TED BAMBINO BOB NASH
JIM SMITH LEIMONE WAITE
FRANK SCHABARUM

DAVID J. COXEY
Secretary/Treasurer/General Manager

BELLA VISTA WATER DISTRICT

11368 E. STILLWATER WAY • REDDING, CALIFORNIA 96003-9510
TELEPHONE (530) 241-1085 • FAX (530) 241-8354

March 19, 2020

Don Bader, Area Manager
U.S. Bureau of Reclamation
Northern California Area Office
16349 Shasta Dam Blvd.
Shasta Lake, CA 96019-8400

Re: Meter Used to Measure Bureau Supplied Water for Payment

Dear Mr. Bader:

The following is the information being provided:

1. Location: Wintu Pump Plant
580 Hilltop Drive, Redding, CA 96003
2. Manufacturers:

Recorder	GE Fanuc
Flow Transmitter	Fischer-Rosemount – Model No. 3051S1CD1A2E12A1AM5TC1 Low Flow Serial #0297339 High Flow Serial #0298086
3. Model number of recorder: GE 90/30 PLC CPU 374
4. Measurement scale: Recording - 120 cfs = 100%, Totalizer
5. Method used to compute Federal water in acre feet: Direct Read
6. Date installed: Recorder – March 2006; Transmitters – March 2008
7. (a) Date of last testing: March 11, 2020
(b) Meter Tester: Randy Olsen, BVWD Electrical/Instrumentation Technician

We are an equal opportunity employer and provider.

8. Description of maintenance schedule: daily visual inspection, cleaning when necessary, lubrication and calibration annually.

9. Who reads the meter: District water treatment operators: Will Markword, Mark Maty, Joe Pedersen, Brad Solso, Tom Zaharris and Electrician, Randy Olsen.

Attached is a copy of the Flow Meter Verification record sheet. If you require further information, please contact me at (530) 241-1085 ext. 201.

Sincerely,



Tom Zaharris
Water Treatment Superintendent

Enclosure

WINTU PUMP STATION
VENTURI DP FLOW METER VERIFICATION

DATE OF VERIFICATION: 3-11-20

Listed below are the milliamp, transmitter water column readings and the calculated CFS. The first line is the BIF factory settings the HAND written entry is the actual field readings during verification.

Low Range Transmitter	14.820 mA	2"	12.92 CFS
CTP - 4 2" WC	14.820 mA	2"	

High Range Transmitter	5.722mA	2"	12.92 CFS
CTP - 4 2" WC	5.722 mA	2"	

Low Range Transmitter	19.302mA	4"	18.27 CFS
CTP - 3 4" WC	19.302 mA	4"	
	19.34		

High Range Transmitter	6.436 mA	4"	18.27 CFS
CTP - 3 4" WC	6.436 mA	4"	

High Range Transmitter	7.851mA	10"	28.88 CFS
CTP - 2 10" WC	7.851 mA	10"	

High Range Transmitter	20.000mA	172.61"	120 CFS
CTP - 1 172.61" WC	20.000 mA	172.61"	
	19.99		

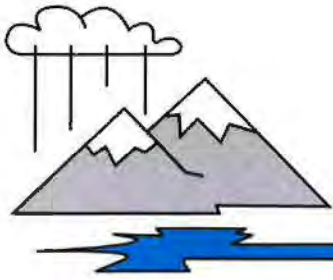

DIRECTORS
TED BAMBINO BOB NASH
JIM SMITH LEIMONE WAITE
FRANK SCHABARUM

DAVID J. COXEY
Secretary/Treasurer/General Manager

BELLA VISTA WATER DISTRICT

11368 E. STILLWATER WAY • REDDING, CALIFORNIA 96003-9510
TELEPHONE (530) 241-1085 • FAX (530) 241-8354

July 21, 2020

SENT VIA EMAIL: DBader@usbr.gov
Don Bader, Area Manager
U.S. Bureau of Reclamation
Northern California Area Office
16349 Shasta Dam Blvd.
Shasta Lake, CA 96019-8400

Re: Wintu Venturi Flow Meter DP Transmitter Failure and Repair

Dear Mr. Bader:

I am writing to inform you about the subject matter. On June 22, 2020 the low range differential pressure transmitter failed on the Wintu Venturi meter. Fortunately, seasonal water demands had increased and we were operating in the high flow range of the venturi except for 110 minutes. June water delivery figures were adjusted accordingly based on the memorandum attached herewith. We ordered a replacement, installed and tested the unit on July 13 and the results of the verifications are listed below.

1. Location: Wintu Pump Plant
580 Hilltop Drive, Redding, CA 96003
2. Manufacturers:

Recorder	GE Fanuc
Flow Transmitter	Fischer-Rosemount – Model No. 3051S1CD1A2E12A1AM5TC1 Low Flow Serial #0297339 High Flow Serial #0298086
3. Model number of recorder: GE 90/30 PLC CPU 374
4. Measurement scale: Recording - 120 cfs = 100%, Totalizer
5. Method used to compute Federal water in acre feet: Direct Read

We are an equal opportunity employer and provider.

Mr. Bader
July 21, 2020
Page 2

6. Date installed: Recorder – March 2006; Transmitters – March 2008
7. (a) Date of last testing: 7/13/2020
(b) Meter Tester: Randy Olsen, BVWD Electrical/Instrumentation Technician
8. Description of maintenance schedule: daily visual inspection, cleaning when necessary, lubrication and calibration annually.
9. Who reads the meter: District water treatment operators: Will Markword, Mark Maty, Joe Pedersen, Brad Solso, Tom Zaharris and Electrician, Randy Olsen.

Attached is a copy of the Flow Meter Verification record sheet. If you require further information, please contact me at (530) 241-1085 ext. 201.

Sincerely,



Tom Zaharris
Water Treatment Superintendent

Enclosure: Copy of Internal Memorandum, dated June 29, 2020
Copy of Failure Verification
Copy of Repaired Verification

MEMORANDUM

TO: Connie Wade,
FROM: Tom Zaharris Tz
RE: Wintu Pumping Adjustment – June 2020
DATE: July 21, 2020 June 29, 2020

On June 6th at about 5:30 p.m., the Rosemount low flow differential pressure transmitter failed on the Wintu Venturi Flow meter. When a 600 hp motor was running at 80% speed the meter should have been reading 3,000 gallons per minute however, when the transmitter failed, the meter defaulted to reading 8,500 gallons a minute. This occurred for approximately 110 minutes for a total of 605,000 gallons over registering. This amount will need to be subtracted from the Wintu flow meter for the month of June to reflect the correct amount pumped from the river. We have been pumping with only the 1,000 hp motors (the high flow differential transmitter records this flow) until we can replace it.

**WINTU PUMP STATION
VENTURI DP FLOW METER VERIFICATION**

DATE OF VERIFICATION: June 22, 2020

Listed below are the milliamp, transmitter water column readings and the calculated CFS. The first line is the BIF factory settings the HAND-written entry is the actual field readings during verification.

Low Range Transmitter CTP - 4 2" WC	14.820 mA <u>12.62</u> mA	2" _____"	12.92 CFS
High Range Transmitter CTP - 4 2" WC	5.722 mA <u>5.75</u> mA	2" _____"	12.92CFS
Low Range Transmitter CTP - 3 4" WC	19.302 mA <u>20.4</u> mA	4" _____"	18.27 CFS
High Range Transmitter CTP - 3 4" WC	6.436 mA <u>6.45</u> mA	4" _____"	18.27 CFS
High Range Transmitter CTP - 2 10" WC	7.851 mA <u>7.85</u> mA	10" _____"	28.88 CFS
High Range Transmitter CTP - 1 172.61" WC	20.000 mA <u>19.98</u> mA	172.61" _____"	120 CFS

**WINTU PUMP STATION
VENTURI DP FLOW METER VERIFICATION**

DATE OF VERIFICATION: July 13, 2020

Listed below are the milliamp, transmitter water column readings and the calculated CFS. The first line is the BIF factory settings the HAND-written entry is the actual field readings during verification.

Low Range Transmitter CTP - 4 2" WC	14.820 mA <u>14.83</u> mA	2" _____"	12.92 CFS
High Range Transmitter CTP - 4 2" WC	5.722 mA _____ mA	2" _____"	12.92CFS
Low Range Transmitter CTP - 3 4" WC	19.302 mA <u>19.30</u> mA	4" _____"	18.27 CFS
High Range Transmitter CTP - 3 4" WC	6.436 mA _____ mA	4" _____"	18.27 CFS
High Range Transmitter CTP - 2 10" WC	7.851 mA _____ mA	10" _____"	28.88 CFS
High Range Transmitter CTP - 1 172.61" WC	20.000 mA _____ mA	172.61" _____"	120 CFS

Pumping Efficiency Testing Services, PETS

Serving you with accuracy and efficiency

498 Water Trough Road
Sebastopol, CA 95472

(866) 774-4812
pumpingefficiency1@pacbell.net

CONFIDENTIAL AND PROPRIETARY INFORMATION PUMPING COST ANALYSIS FROM: Pumping Efficiency Testing Services

TOM ZAHARRIS
BELLA VISTA WATER DISTRICT
11368 EAST STILLWATER WAY
REDDING, CA 960039510

Test Date: 3/6/2019
Pump: WELL 1
Nameplate HP: 125.0
Our Pump Test Number: 114243

This is a Turbine pump used for Municipal and assumed to be operated 1000 hours/year.

The current OPE is high enough that little or no cost savings are estimated from a retrofit/repair.

NOTE: * denotes a value that was Assumed or Provided by Customer	Measured Pump Condition	Assumed Condition After Retrofit	Notes
1. Overall pumping efficiency:	66 %	66 %	
2. Nameplate Horsepower:	125.0 hp	125.0 hp	
3. Motor Efficiency:	92 %	91 %	Note Change!
4. Actual Motor Input Horsepower:	131.0 hp	131.0 hp	
5. Motor loaded at:	96 %	96 %	
6. Flow rate (gpm):	840 gpm	840 gpm	
7. Pumping Level (ft):	130 ft	130 ft	
8. Discharge Pressure (psi):	120 psi	120 psi	
9. Total Dynamic Head (feet):	407 ft	407 ft	Rounded TDH = line 7. + (2.31 x line 8.)
10. Million Gallons Pumped/Year:	50.27 mg/Yr*	50.27 mg/Yr*	Same mg/yr AFTER!
11. Average Cost per kWh:	\$0.170 /kWh*	\$0.170 /kWh*	Same \$/kWh AFTER
			Estimated Savings from Retrofit
12. Estimated Total kWh per Year:	97,700 kWh/yr	97,700 kWh/yr	0 kWh/yr
13. Hours of Operation/yr:	1,000 hr/yr*	1,000 hr/yr	0 hr/yr
14. Kilowatt-Hours per mill gal:	1,938 kWh/mg	1,938 kWh/mg	0 kWh/mg
15. Average Cost Per mill gal:	\$329.52 \$/mg	\$329.52 \$/mg	\$0.00/mg = 0.00%
- Estimated savings = \$0.00/mg = 0.00% of energy costs - If pumping 50.27 mg/year this equals about \$0 annual savings			

Analysis

Remarks:

It is sincerely hoped that this information will prove helpful to you, and that your concerns over maintaining optimum pumping efficiency will continue. If you have any questions, please contact Nancy Comstock at 7078293127.

Regards,

Nancy Comstock

Pumping Efficiency Testing Services, PETS

Serving you with accuracy and efficiency

498 Water Trough Road
Sebastopol, CA 95472

(866) 774-4812
pumpingefficiency1@pacbell.net

Pump Test Report

v.6.0 9/2014

Customer and Facility Data

Pump/Location: Well 1/20809 Old 44 drive **HP:** 125 **Utility:** PG & E
GPS Coord.: **Long** -122.2859 **Lat** 40.55984 **Pump Make:** Peerless
Motor Make: U.S. **Type** Turbine **Meter Number:** 1009984546
Customer Addr: Bella Vista Water District **Serial Number:** HC1024989
11368 East Stillwater Way **Voltage:** 460 **Amps:** 144.5
Redding, CA 960039510
Contact: Tom Zaharris **Our Test #:**
Phone: (530) 241-1085 **Fax:** (530) 241-8354 **Cell:**

Test Results

Test Date: 3/6/2019 **Tester:** Bob Fraker

Run Number ('E' = used for cost anal): E-1
1. Pumping Water Level (ft): 130
2. Standing Water Level (ft): 97.5
3. Draw Down (ft): 33
4. Recovered Water Level (ft): 97.5
5. Discharge Pressure at Gauge (psi): 120
6. Total Lift (ft): 407
7. Flow Velocity (ft/sec): 9.5
8. Measured Flow Rate (gpm): 840
9. Customer Flow Rate (gpm): 837
10. Specific Capacity (gpm/ft draw): 25.8
11. Acre Feet per 24 Hr: 3.7
 Million Gallons per 24 Hr: 1.210
12. Cubic Feet per Second (cfs): 1.9
13. Horsepower Input to Motor: 131
14. Percent of Rated Motor Load (%): 96
15. Kilowatt Input to Motor: 98
16. Kilowatt-hours per mill gal: 1,938
17. Cost to Pump a million gal: \$329.52
18. Energy Cost (\$/hour) \$16.61
19. Base Cost per Kwh: \$0.170
20. Nameplate rpm: 1,770
21. rpm at Gearhead: 0
22. Overall Pumping Efficiency (%): 66

If a Flow Velocity (line 7) is less than 1 ft/second, the accuracy of the test is suspect.

Note any major difference between the "Measured" flow rate and the "Customer's" (lines 8,9).

Remarks

All results are based on conditions during the time of the test. If these conditions vary from the normal operation of your pump, the results shown may not describe the pump's normal performance.
Overall efficiency of this plant is considered to be good assuming this run represents plant's normal operating condition.

Flowmeter: Water Specialties (Serial #932498-8)

Current OPE is close to optimum - no savings estimated for a retrofit

Pumping Efficiency Testing Services, PETS

Serving you with accuracy and efficiency

498 Water Trough Road
Sebastopol, CA 95472

(866) 774-4812

pumpingefficiency1@pacbell.net

CONFIDENTIAL AND PROPRIETARY INFORMATION PUMPING COST ANALYSIS FROM: Pumping Efficiency Testing Services

TOM ZAHARRIS
BELLA VISTA WATER DISTRICT
11368 EAST STILLWATER WAY
REDDING, CA 960039510

Test Date: 3/6/2019
Pump: WELL 2 @ 60 HERTZ
Nameplate HP: 125.0
Our Pump Test Number: 114242

This is a Turbine pump used for Municipal and assumed to be operated 1000 hours/year. Abnormal after-project motor load seen with the reason given as: Reason not given by tester.

The following Pumping Cost Analysis is presented as an estimate prepared from data acquired from the pump test performed 3/6/2019 and information provided by you. Please pay careful attention to the assumptions. The estimated savings are only valid for the assumptions made and conditions measured during the pump test. Note that many numbers are rounded during calculations.

NOTE: * denotes a value that was Assumed or Provided by Customer	Measured Pump Condition	Assumed Condition After Retrofit	Notes
1. Overall pumping efficiency:	59 %	68 %	
2. Nameplate Horsepower:	125.0 hp	125.0 hp	
3. Motor Efficiency:	92 %	91 %	Note Change!
4. Actual Motor Input Horsepower:	107.2 hp	108.8 hp	
5. Motor loaded at:	78 %	80 %	
6. Flow rate (gpm):	650 gpm	750 gpm	
7. Pumping Level (ft):	181 ft	187 ft	
8. Discharge Pressure (psi):	88 psi	88 psi	
9. Total Dynamic Head (feet):	384 ft	391 ft	Rounded TDH = line 7. + (2.31 x line 8.)
10. Million Gallons Pumped/Year:	38.90 mg/Yr*	38.90 mg/Yr*	Same mg/yr AFTER!
11. Average Cost per kWh:	\$0.170 /kWh*	\$0.170 /kWh*	Same \$/kWh AFTER
			Estimated Savings from Retrofit
12. Estimated Total kWh per Year:	80,000 kWh/yr	70,362 kWh/yr	9,638 kWh/yr
13. Hours of Operation/yr:	1,000 hr/yr*	867 hr/yr	133 hr/yr
14. Kilowatt-Hours per mill gal:	2,051 kWh/mg	1,804 kWh/mg	247 kWh/mg
15. Average Cost Per mill gal:	\$348.69 \$/mg	\$306.68 \$/mg	\$42.01/mg = 12.05%
- Estimated savings = \$42.01/mg = 12.05% of energy costs - If pumping 38.90 mg/year this equals about \$1,638 annual savings			

Analysis

Remarks:

It is sincerely hoped that this information will prove helpful to you, and that your concerns over maintaining optimum pumping efficiency will continue. If you have any questions, please contact Nancy Comstock at 7078293127.

Regards,

Nancy Comstock

Pumping Efficiency Testing Services, PETS

Serving you with accuracy and efficiency

498 Water Trough Road
Sebastopol, CA 95472

(866) 774-4812
pumpingefficiency1@pacbell.net

Pump Test Report

v.6.0 9/2014

Customer and Facility Data

Pump/Location:	Well 2 @ 60 Hertz/3050 Crossroads Drive	HP:	125	Utility:	Other
GPS Coord.:	Long -122.2987 Lat 40.56117	Pump Make:	Peerless		
Motor Make:	U.S. Type Turbine	Meter Number:	25330		
Customer Addr:	Bella Vista Water District 11368 East Stillwater Way Redding, CA 960039510	Serial Number:	G95905 / Y08Y153		
Contact:	Tom Zaharris	Voltage:	465	Amps:	165
Phone:	(530) 241-1085	Fax:	(530) 241-8354	Our Test #:	
Cell:					

Test Results

Test Date: 3/6/2019 **Tester:** Bob Fraker

Run Number ('E' = used for cost anal): E-1

1. Pumping Water Level (ft):	181
2. Standing Water Level (ft):	139
3. Draw Down (ft):	42
4. Recovered Water Level (ft):	139
5. Discharge Pressure at Gauge (psi):	88
6. Total Lift (ft):	384
7. Flow Velocity (ft/sec):	7.4
8. Measured Flow Rate (gpm):	650
9. Customer Flow Rate (gpm):	760
10. Specific Capacity (gpm/ft draw):	15.5
11. Acre Feet per 24 Hr:	2.9
Million Gallons per 24 Hr:	0.936
12. Cubic Feet per Second (cfs):	1.4
13. Horsepower Input to Motor:	107
14. Percent of Rated Motor Load (%):	78
15. Kilowatt Input to Motor:	80
16. Kilowatt-hours per mill gal:	2,051
17. Cost to Pump a million gal:	\$348.69
18. Energy Cost (\$/hour)	\$13.60
19. Base Cost per Kwh:	\$0.170
20. Nameplate rpm:	1,775
21. rpm at Gearhead:	0
22. Overall Pumping Efficiency (%):	59

If a Flow Velocity (line 7) is less than 1 ft/second, the accuracy of the test is suspect.

Note any major difference between the "Measured" flow rate and the "Customer's" (lines 8,9).

Remarks

All results are based on conditions during the time of the test. If these conditions vary from the normal operation of your pump, the results shown may not describe the pump's normal performance.

Overall efficiency of this plant is considered to be fair assuming this run represents plant's normal operating condition.

Meter Hours: 5951

Flowmeter: Water Specialties (Serial #951963-8)

Estimated savings of 81 kWh/AF and \$1,638.47 annual energy costs from a retrofit

Current OPE of 59% and estimated potential OPE of 68%

Pumping Efficiency Testing Services, PETS

Serving you with accuracy and efficiency

498 Water Trough Road
Sebastopol, CA 95472

(866) 774-4812
pumpingefficiency1@pacbell.net

CONFIDENTIAL AND PROPRIETARY INFORMATION PUMPING COST ANALYSIS FROM: Pumping Efficiency Testing Services

TOM ZAHARRIS
BELLA VISTA WATER DISTRICT
11368 EAST STILLWATER WAY
REDDING, CA 960039510

Test Date: 3/6/2019
Pump: WELL 3
Nameplate HP: 75.0
Our Pump Test Number: 114239

This is a Submersible pump used for Municipal and assumed to be operated 1000 hours/year. Abnormal after-project motor load seen with the reason given as: Reason not given by tester.

The current OPE is high enough that little or no cost savings are estimated from a retrofit/repair.

NOTE: * denotes a value that was Assumed or Provided by Customer	Measured Pump Condition	Assumed Condition After Retrofit	Notes
1. Overall pumping efficiency:	66 %	66 %	
2. Nameplate Horsepower:	75.0 hp	100.0 hp	Note Change!
3. Motor Efficiency:	85 %	96 %	Note Change!
4. Actual Motor Input Horsepower:	71.0 hp	71.0 hp	
5. Motor loaded at:	81 %	60 %	
6. Flow rate (gpm):	547 gpm	547 gpm	
7. Pumping Level (ft):	81 ft	81 ft	
8. Discharge Pressure (psi):	113 psi	113 psi	
9. Total Dynamic Head (feet):	342 ft	342 ft	Rounded TDH = line 7. + (2.31 x line 8.)
10. Million Gallons Pumped/Year:	32.73 mg/Yr*	32.73 mg/Yr*	Same mg/yr AFTER!
11. Average Cost per kWh:	\$0.170 /kWh*	\$0.170 /kWh*	Same \$/kWh AFTER
			Estimated Savings from Retrofit
12. Estimated Total kWh per Year:	53,000 kWh/yr	53,000 kWh/yr	0 kWh/yr
13. Hours of Operation/yr:	1,000 hr/yr*	1,000 hr/yr	0 hr/yr
14. Kilowatt-Hours per mill gal:	1,615 kWh/mg	1,615 kWh/mg	0 kWh/mg
15. Average Cost Per mill gal:	\$274.50 \$/mg	\$274.50 \$/mg	\$0.00/mg = 0.00%
- Estimated savings = \$0.00/mg = 0.00% of energy costs - If pumping 32.73 mg/year this equals about \$0 annual savings			

Analysis

Remarks:

It is sincerely hoped that this information will prove helpful to you, and that your concerns over maintaining optimum pumping efficiency will continue. If you have any questions, please contact Nancy Comstock at 7078293127.

Regards,

Nancy Comstock

Pumping Efficiency Testing Services, PETS

Serving you with accuracy and efficiency

498 Water Trough Road
Sebastopol, CA 95472

(866) 774-4812
pumpingefficiency1@pacbell.net

Pump Test Report

v.6.0 9/2014

Customer and Facility Data

Pump/Location: Well 3/12054 Old Oregon Trail **HP:** 75 **Utility:** PG & E
GPS Coord.: **Long** -122.2401 **Lat** 40.55145 **Pump Make:**
Motor Make: **Type** Submersible **Meter Number:** 1008826968
Customer Addr: Bella Vista Water District **Serial Number:**
11368 East Stillwater Way **Voltage:** **Amps:**
Redding, CA 960039510 **Our Test #:**
Contact: Tom Zaharris
Phone: (530) 241-1085 **Fax:** (530) 241-8354 **Cell:**

Test Results

Test Date: 3/6/2019 **Tester:** Bob Fraker

Run Number ('E' = used for cost anal): E-1

1. Pumping Water Level (ft): 81
2. Standing Water Level (ft): 36
3. Draw Down (ft): 45
4. Recovered Water Level (ft): 36
5. Discharge Pressure at Gauge (psi): 113
6. Total Lift (ft): 342
7. Flow Velocity (ft/sec): 6.2
8. Measured Flow Rate (gpm): 547
9. Customer Flow Rate (gpm): 440
10. Specific Capacity (gpm/ft draw): 12.3
11. Acre Feet per 24 Hr: 2.4
 Million Gallons per 24 Hr: 0.788
12. Cubic Feet per Second (cfs): 1.2
13. Horsepower Input to Motor: 71
14. Percent of Rated Motor Load (%): 81
15. Kilowatt Input to Motor: 53
16. Kilowatt-hours per mill gal: 1,615
17. Cost to Pump a million gal: \$274.50
18. Energy Cost (\$/hour) \$9.01
19. Base Cost per Kwh: \$0.170
20. Nameplate rpm: 0
21. rpm at Gearhead: 0
22. Overall Pumping Efficiency (%): 66

If a Flow Velocity (line 7) is less than 1 ft/second, the accuracy of the test is suspect.

Note any major difference between the "Measured" flow rate and the "Customer's" (lines 8,9).

Remarks

All results are based on conditions during the time of the test. If these conditions vary from the normal operation of your pump, the results shown may not describe the pump's normal performance.

Overall efficiency of this plant is considered to be good assuming this run represents plant's normal operating condition.

Meter Hours: 39028

Flowmeter: McCrometer (Serial #86 6 4 10)

Current OPE is close to optimum - no savings estimated for a retrofit

Pumping Efficiency Testing Services, PETS

Serving you with accuracy and efficiency

498 Water Trough Road
Sebastopol, CA 95472

(866) 774-4812
pumpingefficiency1@pacbell.net

CONFIDENTIAL AND PROPRIETARY INFORMATION PUMPING COST ANALYSIS FROM: Pumping Efficiency Testing Services

TOM ZAHARRIS
BELLA VISTA WATER DISTRICT
11368 EAST STILLWATER WAY
REDDING, CA 960039510

Test Date: 3/6/2019
Pump: WELL 4
Nameplate HP: 40.0
Our Pump Test Number: 114240

This is a Turbine pump used for Municipal and assumed to be operated 1000 hours/year.

The following Pumping Cost Analysis is presented as an estimate prepared from data acquired from the pump test performed 3/6/2019 and information provided by you. Please pay careful attention to the assumptions. The estimated savings are only valid for the assumptions made and conditions measured during the pump test. Note that many numbers are rounded during calculations.

<i>NOTE: * denotes a value that was Assumed or Provided by Customer</i>	Measured Pump Condition	Assumed Condition After Retrofit	Notes
1. Overall pumping efficiency:	51 %	65 %	
2. Nameplate Horsepower:	40.0 hp	40.0 hp	
3. Motor Efficiency:	94 %	94 %	
4. Actual Motor Input Horsepower:	40.5 hp	40.5 hp	
5. Motor loaded at:	95 %	95 %	
6. Flow rate (gpm):	233 gpm	290 gpm	
7. Pumping Level (ft):	158 ft	163 ft	
8. Discharge Pressure (psi):	85 psi	85 psi	
9. Total Dynamic Head (feet):	354 ft	359 ft	Rounded TDH = line 7. + (2.31 x line 8.)
10. Million Gallons Pumped/Year:	13.94 mg/Yr*	13.94 mg/Yr*	Same mg/yr AFTER!
11. Average Cost per kWh:	\$0.170 /kWh*	\$0.170 /kWh*	Same \$/kWh AFTER
			Estimated Savings from Retrofit
12. Estimated Total kWh per Year:	30,220 kWh/yr	24,276 kWh/yr	5,944 kWh/yr
13. Hours of Operation/yr:	1,000 hr/yr*	803 hr/yr	197 hr/yr
14. Kilowatt-Hours per mill gal:	2,161 kWh/mg	1,736 kWh/mg	425 kWh/mg
15. Average Cost Per mill gal:	\$367.45 \$/mg	\$295.17 \$/mg	\$72.28/mg = 19.67%
<p>- Estimated savings = \$72.28/mg = 19.67% of energy costs - If pumping 13.94 mg/year this equals about \$1,011 annual savings</p>			

Analysis

Remarks:

It is sincerely hoped that this information will prove helpful to you, and that your concerns over maintaining optimum pumping efficiency will continue. If you have any questions, please contact Nancy Comstock at 7078293127.

Regards,

Nancy Comstock

Pumping Efficiency Testing Services, PETS

Serving you with accuracy and efficiency

498 Water Trough Road
Sebastopol, CA 95472

(866) 774-4812
pumpingeffectivity1@pacbell.net

Pump Test Report

v.6.0 9/2014

Customer and Facility Data

Pump/Location: Well 4/2067 Abernathy Lane **HP:** 40 **Utility:** REU
GPS Coord.: **Long** -122.3149 **Lat** 40.5693 **Pump Make:**
Motor Make: U.S. **Type** Turbine **Meter Number:** 56450
Customer Addr: Bella Vista Water District **Serial Number:** B406A / U04U023R
11368 East Stillwater Way **Voltage:** 460 **Amps:** 45
Redding, CA 960039510 **Our Test #:**
Contact: Tom Zaharris
Phone: (530) 241-1085 **Fax:** (530) 241-8354 **Cell:**

Test Results

Test Date: 3/6/2019 **Tester:** Bob Fraker

Run Number ('E' = used for cost anal): E-1

1. Pumping Water Level (ft): 158
2. Standing Water Level (ft): 137
3. Draw Down (ft): 21
4. Recovered Water Level (ft): 137
5. Discharge Pressure at Gauge (psi): 85
6. Total Lift (ft): 354
7. Flow Velocity (ft/sec): 2.6
8. Measured Flow Rate (gpm): 233
9. Customer Flow Rate (gpm): 0
10. Specific Capacity (gpm/ft draw): 11.1
11. Acre Feet per 24 Hr: 1.0
 Million Gallons per 24 Hr: 0.336
12. Cubic Feet per Second (cfs): 0.5
13. Horsepower Input to Motor: 41
14. Percent of Rated Motor Load (%): 95
15. Kilowatt Input to Motor: 30
16. Kilowatt-hours per mill gal: 2,161
17. Cost to Pump a million gal: \$367.45
18. Energy Cost (\$/hour): \$5.14
19. Base Cost per Kwh: \$0.170
20. Nameplate rpm: 0
21. rpm at Gearhead: 0
22. Overall Pumping Efficiency (%): 51

If a Flow Velocity (line 7) is less than 1 ft/second, the accuracy of the test is suspect.

Note any major difference between the "Measured" flow rate and the "Customer's" (lines 8,9).

Remarks

All results are based on conditions during the time of the test. If these conditions vary from the normal operation of your pump, the results shown may not describe the pump's normal performance.

Overall efficiency of this plant is considered to be fair assuming this run represents plant's normal operating condition.

Meter Hours: 41943

Flowmeter: Water Specialties (Serial #912693)

Estimated savings of 139 kWh/AF and \$1,010.55 annual energy costs from a retrofit

Current OPE of 51% and estimated potential OPE of 65%

Pumping Efficiency Testing Services, PETS

Serving you with accuracy and efficiency

498 Water Trough Road
Sebastopol, CA 95472

(866) 774-4812
pumpingefficiency1@pacbell.net

CONFIDENTIAL AND PROPRIETARY INFORMATION PUMPING COST ANALYSIS FROM: Pumping Efficiency Testing Services

TOM ZAHARRIS
BELLA VISTA WATER DISTRICT
11368 EAST STILLWATER WAY
REDDING, CA 960039510

Test Date: 3/6/2019
Pump: WELL 6
Nameplate HP: 100.0
Our Pump Test Number: 114241

This is a Turbine pump used for Municipal and assumed to be operated 1000 hours/year. Abnormal after-project motor load seen with the reason given as: Reason not given by tester.

The current OPE is high enough that little or no cost savings are estimated from a retrofit/repair.

NOTE: * denotes a value that was Assumed or Provided by Customer	Measured Pump Condition	Assumed Condition After Retrofit	Notes
1. Overall pumping efficiency:	71 %	71 %	
2. Nameplate Horsepower:	100.0 hp	100.0 hp	
3. Motor Efficiency:	93 %	95 %	Note Change!
4. Actual Motor Input Horsepower:	80.4 hp	80.4 hp	
5. Motor loaded at:	75 %	75 %	
6. Flow rate (gpm):	568 gpm	568 gpm	
7. Pumping Level (ft):	143 ft	143 ft	
8. Discharge Pressure (psi):	111 psi	111 psi	
9. Total Dynamic Head (feet):	399 ft	399 ft	Rounded TDH = line 7. + (2.31 x line 8.)
10. Million Gallons Pumped/Year:	33.99 mg/Yr*	33.99 mg/Yr*	Same mg/yr AFTER!
11. Average Cost per kWh:	\$0.170 /kWh*	\$0.170 /kWh*	Same \$/kWh AFTER
			Estimated Savings from Retrofit
12. Estimated Total kWh per Year:	60,000 kWh/yr	60,000 kWh/yr	0 kWh/yr
13. Hours of Operation/yr:	1,000 hr/yr*	1,000 hr/yr	0 hr/yr
14. Kilowatt-Hours per mill gal:	1,760 kWh/mg	1,760 kWh/mg	0 kWh/mg
15. Average Cost Per mill gal:	\$299.27 \$/mg	\$299.27 \$/mg	\$0.00/mg = 0.00%
- Estimated savings = \$0.00/mg = 0.00% of energy costs - If pumping 33.99 mg/year this equals about \$0 annual savings			

Analysis

Remarks:

It is sincerely hoped that this information will prove helpful to you, and that your concerns over maintaining optimum pumping efficiency will continue. If you have any questions, please contact Nancy Comstock at 7078293127.

Regards,

Nancy Comstock

Pumping Efficiency Testing Services, PETS

Serving you with accuracy and efficiency

498 Water Trough Road
Sebastopol, CA 95472

(866) 774-4812
pumpingefficiency1@pacbell.net

Pump Test Report

v.6.0 9/2014

Customer and Facility Data

Pump/Location: Well 6/20620 Old 44 drive **HP:** 100 **Utility:** PG & E
GPS Coord.: **Long** -122.2909 **Lat** 40.56323 **Pump Make:** Peerless
Motor Make: U.S. **Type** Turbine **Meter Number:** 1006727986
Customer Addr: Bella Vista Water District **Serial Number:** B410 V08V189R03
11368 East Stillwater Way **Voltage:** 460 **Amps:** 115
Redding, CA 960039510
Contact: Tom Zaharris **Our Test #:**
Phone: (530) 241-1085 **Fax:** (530) 241-8354 **Cell:**

Test Results

Test Date: 3/6/2019 **Tester:** Bob Fraker

Run Number ('E' = used for cost anal): E-1

1. Pumping Water Level (ft): 143
2. Standing Water Level (ft): 79
3. Draw Down (ft): 64
4. Recovered Water Level (ft): 79
5. Discharge Pressure at Gauge (psi): 111
6. Total Lift (ft): 399
7. Flow Velocity (ft/sec): 6.4
8. Measured Flow Rate (gpm): 568
9. Customer Flow Rate (gpm): 580
10. Specific Capacity (gpm/ft draw): 8.9
11. Acre Feet per 24 Hr: 2.5
 Million Gallons per 24 Hr: 0.818
12. Cubic Feet per Second (cfs): 1.3
13. Horsepower Input to Motor: 80
14. Percent of Rated Motor Load (%): 75
15. Kilowatt Input to Motor: 60
16. Kilowatt-hours per mill gal: 1,760
17. Cost to Pump a million gal: \$299.27
18. Energy Cost (\$/hour) \$10.20
19. Base Cost per Kwh: \$0.170
20. Nameplate rpm: 1,780
21. rpm at Gearhead: 0
22. Overall Pumping Efficiency (%): 71

If a Flow Velocity (line 7) is less than 1 ft/second, the accuracy of the test is suspect.

Note any major difference between the "Measured" flow rate and the "Customer's" (lines 8,9).

Remarks

All results are based on conditions during the time of the test. If these conditions vary from the normal operation of your pump, the results shown may not describe the pump's normal performance.
Overall efficiency of this plant is considered to be very good assuming this run represents plant's normal operating condition.

Meter Hours: 43274

Flowmeter: Water Specialties (Serial #924110)

Pump Nameplate Data: 600 GPM. @ 420' TDH. 1800 RPM.

Current OPE is close to optimum - no savings estimated for a retrofit

ATTACHMENT C.2

Meter Warranty Documents



PRODUCTS COVERED

This warranty shall apply to all Recordall® Lead-Free Bronze Disc Meters, models 25 through 170, when used to measure potable water, including the registers used with these meters (collectively “Product”) sold on or after January 25, 2019. This warranty is extended only to utilities, municipalities, other commercial users and authorized Badger Meter, Inc. distributors, hereafter referred to as “Customer” and does NOT apply to consumers or any person or entity who is not an original customer of Badger Meter or its authorized distributors.

MATERIALS AND WORKMANSHIP

Badger Meter warrants Product to be free from defects in materials and workmanship appearing within the following time frames and those listed in the table below:

Housings

Twenty-five (25) years and six (6) months after shipment from Badger Meter.

Local Registers Supplied with the Meters Listed Herein

Twenty-five (25) years and six (6) months after shipment from Badger Meter.

	AWWA New Meter Accuracy	AWWA Repaired Meter Accuracy (AWWA M6 Manual)	Badger Meter Extended Low Flow Meter Accuracy
Recordall Meter Model, Size	<i>The meter product will meet or exceed new meter accuracy standards set forth in AWWA Standard C700 for the following periods:</i>	<i>The meter product will meet or exceed repaired meter accuracy standards set forth in AWWA Manual M-6, Chapter 5, Table 5.3 for the following periods:</i>	<i>Badger Meter further warrants the meter product to meet or exceed the following extended low flow accuracies in excess of AWWA standard:</i>
Model 25, 5/8 in. and 5/8 x 3/4 in.	Five (5) years from date of shipment or registration of 750,000 gallons, whichever occurs first.	Fifteen (15) years from date of shipment or registration of 2,500,000 gallons, whichever occurs first, with a 25 gpm safe maximum operating capacity and a 15 gpm maximum rate for continuous operation.	Badger Meter warrants Product low flow accuracy of 98.5% at a rate of 1/4 gpm and low flow accuracy of 95.0% at a rate of 1/8 gpm for five (5) years from date of shipment or registration of 675,000 gallons, whichever occurs first.
Model 35, 3/4 in.	Five (5) years from date of shipment or registration of 750,000 gallons, whichever occurs first.	Fifteen (15) years from date of shipment or registration of 2,500,000 gallons, whichever occurs first, with a 35 gpm safe maximum operating capacity and a 25 gpm maximum rate for continuous operation.	Badger Meter warrants Product low flow accuracy of 97% at a rate of 3/8 gpm for five (5) years from date of shipment or registration of 675,000 gallons, whichever occurs first.
Model 55, 1 in.	Five (5) years from date of shipment or registration of 1,000,000 gallons, whichever occurs first.	Fifteen (15) years from date of shipment or registration of 3,000,000 gallons, whichever occurs first, with a 55 gpm safe maximum operating capacity and a 40 gpm maximum rate for continuous operation.	Badger Meter warrants Product low flow accuracy of 95% at a rate of 1/2 gpm for three (3) years from date of shipment or registration of 575,000 gallons, whichever occurs first.
Model 70, 1 in.	Five (5) years from date of shipment or registration of 1,100,000 gallons, whichever occurs first.	Fifteen (15) years from date of shipment or registration of 3,250,000 gallons, whichever occurs first, with a 70 gpm safe maximum operating capacity and a 50 gpm maximum rate for continuous operation.	Badger Meter warrants Product low flow accuracy of 95% at a rate of 3/4 gpm for three (3) years from date of shipment or registration of 1,100,000 gallons, whichever occurs first.
Model 120, 1-1/2 in.	Two (2) years from date of shipment or registration of 1,600,000 gallons, whichever occurs first.	Fifteen (15) years from date of shipment or registration of 5,600,000 gallons, whichever occurs first, with a 120 gpm safe maximum operating capacity and a 80 gpm maximum rate for continuous operation.	Badger Meter warrants Product low flow accuracy of 95% at a rate of 1-1/4 gpm for two (2) years from date of shipment or registration of 1,440,000 gallons, whichever occurs first.
Model 170, 2 in.	Two (2) years from date of shipment or registration of 2,100,000 gallons, whichever occurs first.	Fifteen (15) years from date of shipment or registration of 10,400,000 gallons, whichever occurs first, with a 170 gpm safe maximum operating capacity and a 100 gpm maximum rate for continuous operation.	Badger Meter warrants Product low flow accuracy of 95% at a rate of 1-1/2 gpm for two (2) years from date of shipment or registration of 1,890,000 gallons, whichever occurs first.

PRODUCT RETURNS

Any Product proved to the satisfaction of Badger Meter to have failed the foregoing warranties will, at the option of Badger Meter, be repaired or replaced without charge to the Customer. Any eligible Product repaired or replaced by Badger Meter will retain the original Product's warranty based on the original Product purchase date, at Badger Meter's sole discretion. The Badger Meter obligation hereunder shall be limited to such repair and replacement and shall be conditioned upon Badger Meter receiving written notice of any alleged defect within ten (10) days after its discovery. This exclusive remedy shall not be deemed to have failed its essential purpose so long as Badger Meter is willing and able to replace defective products or issue a credit to purchaser within a reasonable time of proof to Badger Meter that a defect is involved. Product returns must be shipped by the Customer prepaid F.O.B. to the nearest Badger Meter factory or distribution center. The Customer shall be responsible for all direct and indirect costs associated with removing the original Product and reinstalling the repaired or replacement Product.

LIMITS OF LIABILITY

This warranty shall not apply to Product repaired or altered by parties other than Badger Meter. The foregoing warranty applies only to the extent that the Product is installed, serviced and operated strictly in accordance with AWWA Standard C700 and AWWA M6 Manual, as applicable. The warranty shall not apply and shall be void with respect to Product exposed to conditions other than those detailed in the Badger Meter Product technical and/or operational literature, or which have been exposed to adverse installation conditions, damaged by any water conditions and/or water quality, including but not limited to foreign matter in the water such as dirt, sand, minerals, debris, deposits, biofilms, extreme corrosivity, or other impurities, or which have been subject to passage of high-speed air slugs, vandalism, negligence, accident, acts of God, alteration, improper installation, operation or repair, or other circumstances which are beyond the reasonable control of Badger Meter. With respect to Product not manufactured by Badger Meter, the warranty obligations of Badger Meter shall in all respects conform and be limited to the warranty extended to Badger Meter by the supplier.

THE FOREGOING WARRANTIES ARE EXCLUSIVE AND IN LIEU OF ALL OTHER EXPRESS AND IMPLIED WARRANTIES WHATSOEVER, INCLUDING BUT NOT LIMITED TO IMPLIED WARRANTIES OF MERCHANTABILITY AND FITNESS FOR A PARTICULAR PURPOSE (except warranties of Title).

Any description of Product, whether in writing or made orally by Badger Meter or its agents, specifications, samples, models, bulletins, drawings, diagrams, engineering sheets, or similar materials used in connection with any Customer's order are for the sole purpose of identifying Product and shall not be construed as an express warranty. Any suggestions by Badger Meter or its agents regarding use, application or suitability of Product shall not be construed as an express warranty unless confirmed to be such in writing by Badger Meter.

Exclusion of Consequential Damages and Disclaimer of Other Liability

Badger Meter liability with respect to breaches of the foregoing warranty shall be limited as stated therein. Badger Meter liability shall in no event exceed the contract price.

BADGER METER SHALL NOT BE SUBJECT TO AND DISCLAIMS:

- (1) ANY OTHER OBLIGATIONS OR LIABILITIES ARISING OUT OF BREACH OF CONTRACT OR OF WARRANTY
- (2) ANY OBLIGATIONS WHATSOEVER ARISING FROM TORT CLAIMS (INCLUDING NEGLIGENCE AND STRICT LIABILITY) OR ARISING UNDER OTHER THEORIES OF LAW WITH RESPECT TO PRODUCTS SOLD OR SERVICES RENDERED BY BADGER METER, OR ANY UNDERTAKINGS, ACTS OR OMISSIONS RELATING THERETO, AND
- (3) ALL CONSEQUENTIAL, INCIDENTAL AND CONTINGENT DAMAGES WHATSOEVER.

Making Water Visible®

Recordall is a registered trademark of Badger Meter, Inc. Other trademarks appearing in this document are the property of their respective entities. Due to continuous research, product improvements and enhancements, Badger Meter reserves the right to change product or system specifications without notice, except to the extent an outstanding contractual obligation exists. © 2019 Badger Meter, Inc. All rights reserved.

www.badgermeter.com

The Americas | Badger Meter | 4545 West Brown Deer Rd | PO Box 245036 | Milwaukee, WI 53224-9536 | 800-876-3837 | 414-355-0400
México | Badger Meter de las Americas, S.A. de C.V. | Pedro Luis Ogazón N°32 | Esq. Angelina N°24 | Colonia Guadalupe Inn | CP 01050 | México, DF | México | +52-55-5662-0882
Europe, Eastern Europe Branch Office (for Poland, Latvia, Lithuania, Estonia, Ukraine, Belarus) | Badger Meter Europe | ul. Korfantego 6 | 44-193 Knurów | Poland | +48-32-236-8787
Europe, Middle East and Africa | Badger Meter Europa GmbH | Nürtinger Str 76 | 72639 Neuffen | Germany | +49-7025-9208-0
Europe, Middle East Branch Office | Badger Meter Europe | PO Box 341442 | Dubai Silicon Oasis, Head Quarter Building, Wing C, Office #C209 | Dubai / UAE | +971-4-371 2503
Slovakia | Badger Meter Slovakia s.r.o. | Racianska 109/B | 831 02 Bratislava, Slovakia | +421-2-44 63 83 01
Asia Pacific | Badger Meter | 80 Marine Parade Rd | 19-07 Parkway Parade | Singapore 449269 | +65-63464836
Switzerland | Badger Meter Swiss AG | Mittelholzerstrasse 8 | 3006 Bern | Switzerland | +41-31-932 01 11



Badger Meter

E-Series® Ultrasonic Meter

Cold Water Lead-Free Meters
5/8, 5/8 x 3/4, 3/4, 1 inch

PRODUCTS

This warranty shall apply to all Badger Meter E-Series® Ultrasonic lead-free meters (stainless steel, bronze alloy or engineered polymer), sizes 5/8 inch, 5/8 x 3/4 inch, 3/4 inch, and 1 inch, when used to measure potable water and the internal register/encoder and battery used with these meters (collectively "Product"), sold on or after June 28, 2021. This warranty is not transferable and is extended only to utilities, municipalities, other commercial users and authorized distributors, hereafter referred to as "Customer" and does NOT apply to consumers or any person or entity who is not an original customer of Badger Meter or its authorized distributors.

MATERIALS AND WORKMANSHIP

Badger Meter, Inc. ("Badger Meter") warrants Product to be free from defects in materials and workmanship appearing within the earlier of the following time frames.

Lead-Free Housings

Twenty (20) years and six (6) months after shipment from Badger Meter.

Electronics, Battery, Transducers, and Register/Encoder Supplied with the Meters Listed Herein

Twenty (20) years and six (6) months, prorated, after shipment from Badger Meter.

This warranty is prorated as follows: For the first ten (10) years of the warranty the Product is replaced at no charge, and the warranty is prorated at price discounts during the last ten (10) years of the warranty.

Specifically, Badger Meter will repair or replace, at its discretion, a non-performing Product at no cost during the first ten (10) years of the warranty and at prorated price discounts during the last ten (10) years of the warranty. Badger Meter will apply these prorated price discounts to the Product list prices in effect at the time of Product return and according to the following prorated price discount schedule:

- Years 11 through 12—75% discount
- Years 13 through 15—50% discount
- Year 16—40% discount
- Year 17—30% discount
- Year 18—20% discount
- Years 19 through 20—10% discount

Replacement Products are warranted for and under the balance of the original applicable Product warranty.

Pressure Sensor

Five (5) years and six (6) months after shipment from Badger Meter.

This warranty is only applicable for the bronze E-Series G2® Ultrasonic meter with the optional pressure sensor installed.

METER ACCURACY

The Product will meet or exceed all applicable specifications outlined in AWWA Standard C715 in addition to meeting meter accuracy of $\pm 1.5\%$ for the published ranges set forth in Badger Meter's current published product data sheet for twenty (20) years from the date of shipment from Badger Meter.

EXTENDED LOW-FLOW METER ACCURACY

Badger Meter further warrants the Product will meet extended minimum test flow accuracy of $\pm 3\%$ for the published ranges set forth in Badger Meter's current published product data sheet for twenty (20) years from the date of shipment from Badger Meter.

PRODUCT RETURNS

Any Product proved to the satisfaction of Badger Meter to have failed the foregoing warranties will, at the option of Badger Meter, be repaired or replaced without charge to the Customer. Any eligible Product repaired or replaced by Badger Meter will retain the original Product's warranty based on the original Product purchase date, at Badger Meter's sole discretion. The Badger Meter obligation hereunder shall be limited to such repair and replacement and shall be conditioned upon Badger Meter receiving written notice of any alleged defect within ten (10) days after its discovery. This exclusive remedy shall not be deemed to have failed its essential purpose so long as Badger Meter is willing and able to replace defective products or issue a credit to purchaser within a reasonable time of proof to Badger Meter that a defect is involved. Product returns must be shipped by the Customer prepaid F.O.B. to the nearest Badger Meter factory or distribution center. The Customer shall be responsible for all direct and indirect costs associated with removing the original Product and reinstalling the repaired or replacement Product.

LIMITS OF LIABILITY

This warranty shall not apply to Product repaired or altered by parties other than Badger Meter, or read by equipment not explicitly approved or licensed by Badger Meter. The foregoing warranty applies only to the extent that the Product is installed, serviced and operated strictly in accordance with AWWA Standard C715 and AWWA M6 Manual, as applicable. The warranty shall not apply and shall be void with respect to Product exposed to conditions other than those detailed in the Badger Meter Product

technical and/or operational literature, or which, as determined at Badger Meter's sole discretion, have affected the ability of the Product to perform, including, but not limited to: exposure to adverse installation conditions; misuse; vandalism; negligence; accident; acts of God; alteration; improper installation, operation or repair; damage from passage of high-speed air slugs; damage by water quality conditions, including but not limited to: aggressive water, foreign matter, biofilms, or extreme corrosivity; damage caused by actions not in accordance with the intended use; or other circumstances which are beyond the reasonable control of Badger Meter, as determined at Badger Meter's sole discretion. With respect to product not manufactured by Badger Meter, the warranty obligations of Badger Meter shall in all respects conform and be limited to the warranty extended to Badger Meter by the supplier of product.

THE FOREGOING WARRANTIES ARE EXCLUSIVE AND IN LIEU OF ALL OTHER EXPRESS AND IMPLIED WARRANTIES WHATSOEVER, INCLUDING BUT NOT LIMITED TO IMPLIED WARRANTIES OF MERCHANTABILITY AND FITNESS FOR A PARTICULAR PURPOSE (except warranties of Title).

Any description of Product, whether in writing or made orally by Badger Meter or its agents, specifications, samples, models, bulletins, drawings, diagrams, engineering sheets, or similar materials used in connection with any Customer's order are for the sole purpose of identifying Product and shall not be construed as an express warranty. Any suggestions by Badger Meter or its agents regarding use, application or suitability of Product shall not be construed as an express warranty unless confirmed to be such in writing by Badger Meter.

Exclusion of Consequential Damages and Disclaimer of Other Liability

Badger Meter liability with respect to breaches of the foregoing warranty shall be limited as stated therein. Badger Meter liability shall in no event exceed the contract price. BADGER METER SHALL NOT BE SUBJECT TO AND DISCLAIM: (1) ANY OTHER OBLIGATIONS OR LIABILITIES ARISING OUT OF BREACH OF CONTRACT OR OF WARRANTY (2) ANY OBLIGATIONS WHATSOEVER ARISING FROM TORT CLAIMS (INCLUDING NEGLIGENCE AND STRICT LIABILITY) OR ARISING UNDER OTHER THEORIES OF LAW WITH RESPECT TO PRODUCTS SOLD OR SERVICES RENDERED BY BADGER METER, OR ANY UNDERTAKINGS, ACTS OR OMISSIONS RELATING THERETO, AND (3) ALL CONSEQUENTIAL, INCIDENTAL AND CONTINGENT DAMAGES WHATSOEVER.

SMART WATER IS BADGER METER

E-Series and E-Series G2 are registered trademarks of Badger Meter, Inc. Other trademarks appearing in this document are the property of their respective entities. Due to continuous research, product improvements and enhancements, Badger Meter reserves the right to change product or system specifications without notice, except to the extent an outstanding contractual obligation exists. © 2021 Badger Meter, Inc. All rights reserved.



PRODUCTS COVERED

This warranty shall apply to all Recordall® Turbo Series Meters, sizes 1-1/2...12 inch, Turbo Series head assemblies and the local registers used with these meters (collectively “Product”) sold on or after July 27, 2021. This warranty is extended only to utilities, municipalities, other commercial users and authorized Badger Meter, Inc. distributors, hereafter referred to as “Customer” and does NOT apply to consumers or any person or entity who is not an original customer of Badger Meter or its authorized distributors.

MATERIALS AND WORKMANSHIP

Badger Meter warrants Product to be free from defects in materials and workmanship appearing within the following time frames:

Bronze Housing

One (1) year and six (6) months after shipment from Badger Meter.

Local Registers Supplied with the Meters Listed Herein

Five (5) years and six (6) months after shipment from Badger Meter.

METER ACCURACY

The meter Product will meet or exceed accuracy standards of AWWA Standard C701 for one (1) year and six (6) months after shipment from Badger Meter.

PRODUCT RETURNS

Any Product proved to the satisfaction of Badger Meter to have failed the foregoing warranties will, at the option of Badger Meter, be repaired or replaced without charge to the Customer. Any eligible Product repaired or replaced by Badger Meter will retain the original Product’s warranty based on the original Product purchase date, at Badger Meter’s sole discretion. The Badger Meter obligation hereunder shall be limited to such repair and replacement and shall be conditioned upon Badger Meter receiving written notice of any alleged defect within ten (10) days after its discovery. This exclusive remedy shall not be deemed to have failed its essential purpose so long as Badger Meter is willing and able to replace defective products or issue a credit to purchaser within a reasonable time of proof to Badger Meter that a defect is involved. Product returns must be shipped by the Customer prepaid F.O.B. to the nearest Badger Meter factory or distribution center. The Customer shall be responsible for all direct and indirect costs associated with removing the original Product and reinstalling the repaired or replacement Product.

LIMITS OF LIABILITY

This warranty shall not apply to Product repaired or altered by parties other than Badger Meter. The foregoing warranty applies only to the extent that the Product is installed, serviced and operated strictly in accordance with AWWA Standard C715 and AWWA M6 Manual, as applicable. The warranty shall not apply and shall be void with respect to Product exposed to conditions other than those detailed in the Badger Meter Product technical and/or operational literature, or which have been exposed to adverse installation conditions, damaged by any water conditions and/or water quality, including but not limited to foreign matter in the water such as dirt, sand, minerals, debris, deposits, biofilms, extreme corrosivity, or other impurities, or which have been subject to passage of high-speed air slugs, vandalism, negligence, accident, acts of God, alteration, improper installation, operation or repair, or other circumstances which are beyond the reasonable control of Badger Meter. With respect to Product not manufactured by Badger Meter, the warranty obligations of Badger Meter shall in all respects conform and be limited to the warranty extended to Badger Meter by the supplier.

THE FOREGOING WARRANTIES ARE EXCLUSIVE AND IN LIEU OF ALL OTHER EXPRESS AND IMPLIED WARRANTIES WHATSOEVER, INCLUDING BUT NOT LIMITED TO IMPLIED WARRANTIES OF MERCHANTABILITY AND FITNESS FOR A PARTICULAR PURPOSE (except warranties of Title).

Any description of Product, whether in writing or made orally by Badger Meter or its agents, specifications, samples, models, bulletins, drawings, diagrams, engineering sheets, or similar materials used in connection with any Customer’s order are for the sole purpose of identifying Product and shall not be construed as an express warranty. Any suggestions by Badger Meter or its agents regarding use, application or suitability of Product shall not be construed as an express warranty unless confirmed to be such in writing by Badger Meter.

Exclusion of Consequential Damages and Disclaimer of Other Liability

Badger Meter liability with respect to breaches of the foregoing warranty shall be limited as stated therein. Badger Meter liability shall in no event exceed the contract price. BADGER METER SHALL NOT BE SUBJECT TO AND DISCLAIMS: (1) ANY OTHER OBLIGATIONS OR LIABILITIES ARISING OUT OF BREACH OF CONTRACT OR OF WARRANTY (2) ANY OBLIGATIONS WHATSOEVER ARISING FROM TORT CLAIMS (INCLUDING NEGLIGENCE AND STRICT LIABILITY) OR ARISING UNDER OTHER THEORIES OF LAW WITH RESPECT TO PRODUCTS SOLD OR SERVICES RENDERED BY BADGER METER, OR ANY UNDERTAKINGS, ACTS OR OMISSIONS RELATING THERETO, AND (3) ALL CONSEQUENTIAL, INCIDENTAL AND CONTINGENT DAMAGES WHATSOEVER.

SMART WATER IS BADGER METER

Recordall is a registered trademark of Badger Meter, Inc. Other trademarks appearing in this document are the property of their respective entities. Due to continuous research, product improvements and enhancements, Badger Meter reserves the right to change product or system specifications without notice, except to the extent an outstanding contractual obligation exists. © 2021 Badger Meter, Inc. All rights reserved.



Badger Meter

Recordall® Compound Series Meters Sizes 2"...6"

PRODUCTS COVERED

This warranty shall apply to all Recordall® Compound Series Meters, sizes 2"...6", and the local registers used with these meters (collectively "Product") sold on or after July 1, 2013. This warranty is extended only to utilities, municipalities, other commercial users and authorized Badger Meter, Inc. distributors, hereafter referred to as "Customer" and does NOT apply to consumers or any person or entity who is not an original customer of Badger Meter or its authorized distributors.

MATERIALS AND WORKMANSHIP

Badger Meter warrants Product to be free from defects in materials and workmanship appearing within the following time frames:

Bronze Housings

One (1) year and six (6) months after shipment from Badger Meter.

Local Registers for Low Flow Registration (Disc Measuring Element) Supplied with the Meters Listed Herein

Twenty-five (25) years and six (6) months after shipment from Badger Meter.

Local Registers for High Flow Registration (Turbo Measuring Element) Supplied with the Meters Listed Herein

Five (5) years and six (6) months after shipment from Badger Meter.

METER ACCURACY

The meter Product will meet or exceed accuracy standards of AWWA Standard C702 for one (1) year and six (6) months after shipment from Badger Meter.

PRODUCT RETURNS

Any Product proved to the satisfaction of Badger Meter to have failed the foregoing warranties will, at the option of Badger Meter, be repaired or replaced without charge to the Customer. The obligation hereunder of Badger Meter shall be limited to such repair and replacement and shall be conditioned upon Badger Meter receiving written notice of any alleged defect within ten (10) days after its discovery. This exclusive remedy shall not be deemed to have failed its essential purpose so long as Badger Meter is willing and able to replace defective products or issue a credit to purchaser within a reasonable time of proof to Badger Meter that a defect is involved. Product returns must be shipped by the Customer prepaid F.O.B. to the nearest Badger Meter factory or distribution center. The Customer shall be responsible for all direct and indirect costs associated with removing original product and reinstalling the repaired or replacement Product.

LIMITS OF LIABILITY

This warranty shall not apply to Product repaired or altered by any party other than Badger Meter. The foregoing warranty applies only to the extent that the Product is installed, serviced and operated strictly in accordance with AWWA Standard C702 and AWWA M6 Manual. The warranty shall not apply and shall be void with respect to Product exposed to conditions other than those detailed in Badger Meter Product technical literature, or which have been subject to vandalism, negligence, accident, acts of God, improper installation, operation or repair, alteration, or other circumstances which are beyond the reasonable control of Badger Meter. With respect to Product not manufactured by Badger Meter, the warranty obligations of Badger Meter shall in all respects conform and be limited to the warranty extended to Badger Meter by the supplier.

THE FOREGOING WARRANTIES ARE EXCLUSIVE AND IN LIEU OF ALL OTHER EXPRESS AND IMPLIED WARRANTIES WHATSOEVER, INCLUDING BUT NOT LIMITED TO IMPLIED WARRANTIES OF MERCHANTABILITY AND FITNESS FOR A PARTICULAR PURPOSE (except warranties of title).

Any description of the Product, whether in writing or made orally by Badger Meter or Badger Meter agents, specifications, samples, models, bulletins, drawings, diagrams, engineering sheets or similar materials used in connection with any Customer's order are for the sole purpose of identifying the Product and shall not be construed as an express warranty. Any suggestions by Badger Meter or agents of Badger Meter regarding use, application, or suitability of the Product shall not be construed as an express warranty unless confirmed to be such in writing by Badger Meter.

Exclusion of Consequential Damages and Disclaimer of Other Liability. The liability of Badger Meter with respect to breaches of the foregoing warranty shall be limited as stated herein. The liability of Badger Meter shall in no event exceed the contract price. **BADGER METER SHALL NOT BE SUBJECT TO AND DISCLAIMS: (1) ANY OTHER OBLIGATIONS OR LIABILITIES ARISING OUT OF BREACH OF CONTRACT OR OF WARRANTY, (2) ANY OBLIGATIONS WHATSOEVER ARISING FROM TORT CLAIMS (INCLUDING NEGLIGENCE AND STRICT LIABILITY) OR ARISING UNDER OTHER THEORIES OF LAW WITH RESPECT TO PRODUCTS SOLD OR SERVICES RENDERED BY BADGER METER, OR ANY UNDERTAKINGS, ACTS OR OMISSIONS RELATING THERETO, AND (3) ALL CONSEQUENTIAL, INCIDENTAL, AND CONTINGENT DAMAGES WHATSOEVER.**

Recordall is a registered trademark of Badger Meter, Inc. Other trademarks appearing in this document are the property of their respective entities.

Due to continuous research, product improvements and enhancements, Badger Meter reserves the right to change product or system specifications without notice, except to the extent an outstanding contractual obligation exists. © 2013 Badger Meter, Inc. All rights reserved.

www.badgermeter.com

The Americas | Badger Meter | 4545 West Brown Deer Rd | PO Box 245036 | Milwaukee, WI 53224-9536 | 800-876-3837 | 414-355-0400

México | Badger Meter de las Americas, S.A. de C.V. | Pedro Luis Ogazón N°32 | Esq. Angelina N°24 | Colonia Guadalupe Inn | CP 01050 | México, DF | México | +52-55-5662-0882

Europe, Middle East and Africa | Badger Meter Europa GmbH | Nurtinger Str 76 | 72639 Neuffen | Germany | +49-7025-9208-0

Czech Republic | Badger Meter Czech Republic s.r.o. | Mařikova 2082/26 | 621 00 Brno, Czech Republic | +420-5-41420411

Slovakia | Badger Meter Slovakia s.r.o. | Racianska 109/B | 831 02 Bratislava, Slovakia | +421-2-44 63 83 01

Asia Pacific | Badger Meter | 80 Marine Parade Rd | 21-04 Parkway Parade | Singapore 449269 | +65-63464836

China | Badger Meter | Rm 501, N° 11 Longyue Apartment | N° 180 Longjin Rd, Jiuting Songjiang District | Shanghai, China | 201615 | +86-21-5763 5412

C-35

Legacy Document #: RCS-W-1-EN



PRODUCTS COVERED

This warranty shall apply to all Recordall® Combo Meters, size 8 inch, and the registers and encoders used with these meters (collectively “Product”) sold on or after September 15, 2017. This warranty is extended only to utilities, municipalities, other commercial users and authorized Badger Meter, Inc. distributors, hereafter referred to as “Customer,” and does NOT apply to consumers or any person or entity who is not an original customer of Badger Meter or its authorized distributors.

MATERIALS AND WORKMANSHIP

Badger Meter warrants Product to be free from defects in materials and workmanship appearing within one (1) year and six (6) months after shipment from Badger Meter.

Housings

One (1) year and six (6) months after shipment from Badger Meter.

**Local Registers for Disc Meter
Supplied with the Meters Listed Herein**

Twenty-five (25) years and six (6) months after shipment from Badger Meter.

**Local Registers for 8 in. Turbo Series Meters
Supplied with the Meters Listed Herein**

Five (5) years and six (6) months after shipment from Badger Meter.

METER ACCURACY

The meter Product will meet or exceed accuracy standards of AWWA Standard C702 for one (1) year and six (6) months after shipment from Badger Meter.

PRODUCT RETURNS

Any Product proved to the satisfaction of Badger Meter to have failed the foregoing warranties will, at the option of Badger Meter, be repaired or replaced without charge to the Customer. The obligation hereunder of Badger Meter shall be limited to such repair and replacement and shall be conditioned upon Badger Meter receiving written notice of any alleged defect within ten (10) days after its discovery. This exclusive remedy shall not be deemed to have failed its essential purpose so long as Badger Meter is willing and able to replace defective products or issue a credit to purchaser within a reasonable time of proof to Badger Meter that a defect is involved. Product returns must be shipped by the Customer prepaid F.O.B. to the nearest Badger Meter factory or distribution center. The Customer shall be responsible for all direct and indirect costs associated with removing original product and reinstalling the repaired or replacement Product.

LIMITS OF LIABILITY

This warranty shall not apply to Product repaired or altered by any party other than Badger Meter. The foregoing warranty applies only to the extent that the Product is installed, serviced and operated strictly in accordance with AWWA Standard C702 and the AWWA M6 Manual. The warranty shall not apply and shall be void with respect to Product exposed to conditions other than those detailed in Badger Meter Product technical literature, or which have been subject to vandalism, negligence, accident, acts of God, improper installation, operation or repair, alteration, or other circumstances which are beyond the reasonable control of Badger Meter. With respect to Product not manufactured by Badger Meter, the warranty obligations of Badger Meter shall in all respects conform and be limited to the warranty extended to Badger Meter by the supplier.

THE FOREGOING WARRANTIES ARE EXCLUSIVE AND IN LIEU OF ALL OTHER EXPRESS AND IMPLIED WARRANTIES WHATSOEVER, INCLUDING BUT NOT LIMITED TO IMPLIED WARRANTIES OF MERCHANTABILITY AND FITNESS FOR A PARTICULAR PURPOSE (except warranties of title).

Any description of the Product, whether in writing or made orally by Badger Meter or Badger Meter agents, specifications, samples, models, bulletins, drawings, diagrams, engineering sheets or similar materials used in connection with any Customer’s order are for the sole purpose of identifying the Product and shall not be construed as an express warranty. Any suggestions by Badger Meter or agents of Badger Meter regarding use, application, or suitability of the Product shall not be construed as an express warranty unless confirmed to be such in writing by Badger Meter.

Exclusion of Consequential Damages and Disclaimer of Other Liability

The liability of Badger Meter with respect to breaches of the foregoing warranty shall be limited as stated herein. The liability of Badger Meter shall in no event exceed the contract price. BADGER METER SHALL NOT BE SUBJECT TO AND DISCLAIMS: (1) ANY OTHER OBLIGATIONS OR LIABILITIES ARISING OUT OF BREACH OF CONTRACT OR OF WARRANTY, (2) ANY OBLIGATIONS WHATSOEVER ARISING FROM TORT CLAIMS (INCLUDING NEGLIGENCE AND STRICT LIABILITY) OR ARISING UNDER OTHER THEORIES OF LAW WITH RESPECT TO PRODUCTS SOLD OR SERVICES RENDERED BY BADGER METER, OR ANY UNDERTAKINGS, ACTS OR OMISSIONS RELATING THERETO, AND (3) ALL CONSEQUENTIAL, INCIDENTAL, AND CONTINGENT DAMAGES WHATSOEVER.

Making Water Visible®

Making Water Visible and Recordall are registered trademarks of Badger Meter, Inc. Other trademarks appearing in this document are the property of their respective entities. Due to continuous research, product improvements and enhancements, Badger Meter reserves the right to change product or system specifications without notice, except to the extent an outstanding contractual obligation exists. © 2017 Badger Meter, Inc. All rights reserved.

www.badgermeter.com

The Americas | Badger Meter | 4545 West Brown Deer Rd | PO Box 245036 | Milwaukee, WI 53224-9536 | 800-876-3837 | 414-355-0400
México | Badger Meter de las Americas, S.A. de C.V. | Pedro Luis Ogazón N°32 | Esq. Angelina N°24 | Colonia Guadalupe Inn | CP 01050 | México, DF | México | +52-55-5662-0882
Europe, Eastern Europe Branch Office (for Poland, Latvia, Lithuania, Estonia, Ukraine, Belarus) | Badger Meter Europe | ul. Korfantego 6 | 44-193 Knurów | Poland | +48-32-236-8787
Europe, Middle East and Africa | Badger Meter Europa GmbH | Nurtinger Str 76 | 72639 Neuffen | Germany | +49-7025-9208-0
Europe, Middle East Branch Office | Badger Meter Europe | PO Box 341442 | Dubai Silicon Oasis, Head Quarter Building, Wing C, Office #C209 | Dubai / UAE | +971-4-371 2503
Slovakia | Badger Meter Slovakia s.r.o. | Racianska 109/B | 831 02 Bratislava, Slovakia | +421-2-44 63 83 01
Asia Pacific | Badger Meter | 80 Marine Parade Rd | 21-06 Parkway Parade | Singapore 449269 | +65-63464836
China | Badger Meter | 7-1202 | 99 Hangzhong Road | Minhang District | Shanghai | China 201101 | +86-21-5763 5412
Switzerland | Badger Meter Swiss AG | Mittelholzerstrasse 8 | 3006 Bern | Switzerland | +41-31-932 01 11



PRODUCTS

This warranty shall apply to Badger Meter Equipment and Parts hereafter referred to as “Product(s)”, as identified on page 2 of this document, sold on or after July 1, 2019. This warranty is not transferable and is extended only to utilities, municipalities, other commercial users and authorized distributors, hereafter referred to as “Customer” and does NOT apply to consumers or any person or entity who is not an original customer of Badger Meter or its authorized distributors.

MATERIALS AND WORKMANSHIP

Badger Meter warrants Product to be free from defects in materials and workmanship appearing within the earlier of either: two (2) years after installation; or two (2) years and six (6) months after shipment from Badger Meter.

PRODUCT RETURNS

Product failures must be proven and verified to the satisfaction of Badger Meter. The obligation of Badger Meter hereunder shall be limited to such repair and replacement and shall be conditioned upon Badger Meter receiving written notice of any alleged defect within ten (10) days after its discovery. This exclusive remedy shall not be deemed to have failed its essential purpose so long as Badger Meter is willing and able to replace defective Product to Customer within a reasonable time after receipt of proof that a defect is involved. Product returns must be shipped by the Customer prepaid CPT to the nearest Badger Meter factory or distribution center. The Customer shall be responsible for all direct and indirect costs associated with removing original Product and reinstalling the repaired or replacement Product.

LIMITS OF LIABILITY

This warranty shall not apply to any Product repaired or altered by any Party other than Badger Meter. The foregoing warranty applies only to the extent that the Product is installed, serviced and operated strictly in accordance with instructions from Badger Meter. The warranty shall not apply and shall be void with respect to Product exposed to conditions other than those detailed in Product technical literature, or which have been subject to vandalism, negligence, accident, acts of God, improper installation, operation or repair, alteration, or other circumstances which are beyond the reasonable control of Badger Meter. With respect to equipment and parts not manufactured by Badger Meter, the warranty obligations of Badger Meter shall in all respects conform and be limited to the warranty extended to Badger Meter by the supplier.

THE FOREGOING WARRANTIES ARE EXCLUSIVE AND IN LIEU OF ALL OTHER EXPRESS AND IMPLIED WARRANTIES WHATSOEVER, INCLUDING BUT NOT LIMITED TO IMPLIED WARRANTIES OF MERCHANT ABILITY AND FITNESS FOR A PARTICULAR PURPOSE (except warranties of title).

Any description of the Product, whether in writing or made orally by Badger Meter or agents of Badger Meter, specifications, samples, models, bulletins, drawings, diagrams, engineering sheets or similar materials used in connection with any order from the Customer are for the sole purpose of identifying the Product and shall not be construed as an express warranty. Any suggestions by Badger Meter or agents of Badger Meter regarding use, application or suitability of the Product shall not be construed as an express warranty unless confirmed to be such in writing by Badger Meter.

Exclusion of Consequential Damages and Disclaimer of Other Liability

The liability of Badger Meter with respect to breaches of the foregoing warranty shall be limited as stated herein. The liability of Badger Meter shall in no event exceed the contract price. **BADGER METER SHALL NOT BE SUBJECT TO AND DISCLAIMS: (1) ANY OTHER OBLIGATIONS OR LIABILITIES ARISING OUT OF BREACH OF CONTRACT OR OF WARRANTY, (2) ANY OBLIGATIONS WHATSOEVER ARISING FROM TORT CLAIMS (INCLUDING NEGLIGENCE AND STRICT LIABILITY) OR ARISING UNDER OTHER THEORIES OF LAW WITH RESPECT TO PRODUCTS SOLD OR SERVICES RENDERED BY BADGER METER, OR ANY UNDERTAKINGS, ACTS OR OMISSIONS RELATING THERETO, AND (3) ALL CONSEQUENTIAL, INCIDENTAL AND CONTINGENT DAMAGES WHATSOEVER.**

PRODUCTS GOVERNED BY THIS TWO-YEAR WARRANTY POLICY

ModMAG® M-Series® Mag Meters

Dynasonics® TFX-500w and TFX-5000 Ultrasonic Clamp-On Meters

Control. Manage. Optimize.

Dynasonics, ModMAG and M-Series are registered trademarks of Badger Meter, Inc. Other trademarks appearing in this document are the property of their respective entities. Due to continuous research, product improvements and enhancements, Badger Meter reserves the right to change product or system specifications without notice, except to the extent an outstanding contractual obligation exists. © 2019 Badger Meter, Inc. All rights reserved.

www.badgermeter.com

The Americas | Badger Meter | 4545 West Brown Deer Rd | PO Box 245036 | Milwaukee, WI 53224-9536 | 800-876-3837 | 414-355-0400
México | Badger Meter de las Americas, S.A. de C.V. | Pedro Luis Ogazón N°32 | Esq. Angelina N°24 | Colonia Guadalupe Inn | CP 01050 | México, DF | México | +52-55-5662-0882
Europe, Eastern Europe Branch Office (for Poland, Latvia, Lithuania, Estonia, Ukraine, Belarus) | Badger Meter Europe | ul. Korfantego 6 | 44-193 Knurów | Poland | +48-32-236-8787
Europe, Middle East and Africa | Badger Meter Europa GmbH | Nurtinger Str 76 | 72639 Neuffen | Germany | +49-7025-9208-0
Europe, Middle East Branch Office | Badger Meter Europe | PO Box 341442 | Dubai Silicon Oasis, Head Quarter Building, Wing C, Office #C209 | Dubai / UAE | +971-4-371 2503
Slovakia | Badger Meter Slovakia s.r.o. | Racianska 109/B | 831 02 Bratislava, Slovakia | +421-2-44 63 83 01
Asia Pacific | Badger Meter | 80 Marine Parade Rd | 19-07 Parkway Parade | Singapore 449269 | +65-63464836
Switzerland | Badger Meter Swiss AG | Mittelholzerstrasse 8 | 3006 Bern | Switzerland | +41-31-932 01 11

ATTACHMENT C.3

Meter Product Data Sheets

DESCRIPTION

The Badger Meter Recordall® (RCDL) positive displacement meters are one of the most cost effective methods in metering industrial fluids. The RCDL meter has a simple, efficient design for high accuracy and repeatability over the entire meter flow range.

Available in sizes 1/2...2 in. for flows up to 170 gpm, these meters are extremely rugged and reliable. Maintenance is seldom required, but if necessary, takes only a few minutes. All parts are designed and built of materials that meet your application requirements and provide an enduring and a trouble-free, precision flow meter.

To complement the RCDL meter line, Badger Meter offers a complete line of accessories that includes totalizers, transmitters, rate of flow indicators and batch/process controllers.

OPERATION

The metering principle, known as positive displacement, is based on the continuous filling and discharging of the measuring chamber. Controlled clearances between the disc and the chamber provide precise measurement of each volume cycle. As the disc nutates, the center spindle rotates a magnet. The movement of the magnet is sensed through the meter wall by a follower magnet or by various sensors. Each revolution of the magnet is equivalent to a fixed volume of fluid, which is converted to any engineering unit of measure for totalization, indication or process control.

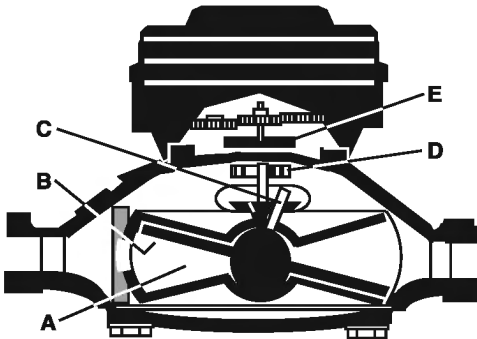

Liquid flowing through the meter chamber (A) causes a disc (B) to nutate or wobble. This motion, in turn, results in the rotation of a spindle (C) and drive magnet (D). Rotation is transmitted through the wall of the meter to a second magnet (E) or varied style of sensor pickup.



LEAD-FREE MODELS AVAILABLE

The Recordall Disc Series meters meet or exceed the most recent revision of AWWA Standard C700 and are available in a lead-free bronze alloy. The meters comply with the lead-free provisions of the Safe Drinking Water Act, are certified to NSF/ANSI/CAN Standards 61 and 372 and carry the NSF-61 mark on the housing. All components of the lead-free bronze alloy meter (housing, measuring element, seals, and so on) comprise the certified system.

FEATURES

- Wide flow range
- Rugged bronze or thermoplastic housing
- Meters available up to 250° F (see ["Temperature Chart" on page 2](#))
- Easily maintained without removing from line
- Durable components for minimal maintenance
- Wide range of compatible accessories

PERFORMANCE

- Accuracy: $\pm 1.5\%$
- Repeatability: $\pm 0.5\%$
- Pressure Range: up to 150 psi
- Temperature Range: 32...250° F

TEMPERATURE CHART

Meter Model	Meter Size	Housing Material	Chamber/Disc Material	Fluid	Temperature Range
M25	5/8 in. (15 mm)	lead-free bronze alloy	engineered polymer	cold liquids	32...120° F (0...49° C)
M25	3/4 in. (15 mm)	lead-free bronze alloy	engineered polymer	cold liquids	32...120° F (0...49° C)
M35	3/4 in. (20 mm)	lead-free bronze alloy	engineered polymer	cold liquids	32...120° F (0...49° C)
M55	1 in. (25 mm)	lead-free bronze alloy	engineered polymer	cold liquids	32...120° F (0...49° C)
M70	1 in. (25 mm)	lead-free bronze alloy	engineered polymer	cold liquids	32...120° F (0...49° C)
M120	1-1/2 in. (40 mm)	lead-free bronze alloy	engineered polymer	cold liquids	32...120° F (0...49° C)
M170	2 in. (50 mm)	lead-free bronze alloy	engineered polymer	cold liquids	32...120° F (0...49° C)
M25	5/8 in. (15 mm)	engineered polymer	engineered polymer	cold liquids	32...100° F (0...38° C)
M25	3/4 in. (20 mm)	engineered polymer	engineered polymer	cold liquids	32...100° F (0...38° C)
M25*	5/8 in. (15 mm)	lead-free bronze alloy	LCP	high temp or chemical	32...250° F (0...121° C)
M25*	3/4 in. (20 mm)	lead-free bronze alloy	LCP	high temp or chemical	32...250° F (0...121° C)
M70*	1 in. (25 mm)	lead-free bronze alloy	LCP	high temp or chemical	32...250° F (0...121° C)
M120*	1-1/2 in. (40 mm)	lead-free bronze alloy	LCP	chemical	32...110° F (0...43° C)

* Model is not certified to NSF/ANSI/CAN Standards 61 and 372

METER SPUD AND CONNECTION SIZES

Model	Size Designation in.	×	"L" Laying Length	"B" Bore Dia.	Coupling Nut and Spud Thread in.	Tailpiece Pipe Thread (NPT) (in.)
25B	5/8	×	7-1/2 in. (190 mm)	5/8 in. (15 mm)	3/4 (5/8)	1/2
	5/8 x 3/4	×	7-1/2 in. (190 mm)	5/8 in. (15 mm), 3/4 in. (20 mm)	1 (3/4)	3/4
25P	5/8	×	7-1/2 in. (190 mm)	5/8 in. (15 mm)	3/4 (5/8)	1/2
	5/8 x 3/4	×	7-1/2 in. (190 mm)	5/8 in. (15 mm), 3/4 in. (20 mm)	1 (3/4)	3/4
	3/4	×	9 in. (229 mm)	3/4 in. (20 mm)	1 (3/4)	3/4
35B	3/4	×	7-1/2 in. (190 mm)	3/4 in. (20 mm)	1 (3/4)	3/4
	3/4	×	9 in. (229 mm)	3/4 in. (20 mm)	1 (3/4)	3/4
	3/4 x 1	×	9 in. (229 mm)	3/4 in. (20 mm)	1-1/4 (1)	1
55B	1	×	10-3/4 in. (273 mm)	1 in. (25 mm)	1-1/4 (1)	1
70B	1	×	10-3/4 in. (273 mm)	1 in. (25 mm)	1-1/4 (1)	1

NOTE:

The engineering thread is always one thread size larger than the meter size or service pipe thread designation. Under *Coupling Nut and Spud Thread*, the size given in parentheses identifies the size to specify when ordering meter connections, such as tailpiece couplings.

MATERIALS

Model	Model 25 Polymer	Model 25 Bronze	Model 35 Bronze	Model 55 Bronze	Model 70 Bronze	Model 120 Bronze	Model 170 Bronze
Size Designation	5/8 in. 5/8 x 3/4 in. 3/4 in.	5/8 in. 5/8 x 3/4 in.	3/4 in.	1 in.	1 in.	1-1/2 in.	2 in.
Meter Housing	Engineered polymer	Lead-free bronze alloy	Lead-free bronze alloy	Lead-free bronze alloy	Lead-free bronze alloy	Lead-free bronze alloy	Lead-free bronze alloy
Housing Bottom Plates	Engineered polymer	Cast iron, lead-free bronze alloy	Cast iron, lead-free bronze alloy	Cast iron, lead-free bronze alloy	Cast iron, lead-free bronze alloy	Lead-free bronze alloy	Lead-free bronze alloy
Measuring Chamber	Engineered polymer	Engineered polymer	Engineered polymer	Engineered polymer	Engineered polymer	Engineered polymer	Engineered polymer
Disc	Engineered polymer	Engineered polymer	Engineered polymer	Engineered polymer	Engineered polymer	Engineered polymer	Engineered polymer
Trim	n/a	Stainless steel	Stainless steel	Stainless steel	Stainless steel	Stainless steel	Stainless steel
Strainer	Engineered polymer	Engineered polymer	Engineered polymer	Engineered polymer	Engineered polymer	Engineered polymer	Engineered polymer
Disc Spindle	Stainless steel	Stainless steel	Stainless steel	Engineered polymer	Stainless steel	Stainless steel	Stainless steel
Magnet	Ceramic	Ceramic	Ceramic	Ceramic	Ceramic	Ceramic	Ceramic
Magnet Spindle	Engineered polymer	Engineered polymer	Stainless steel	Engineered polymer	Engineered polymer	Engineered polymer	Engineered polymer
Register Lid and Shroud	Engineered polymer, bronze	Engineered polymer, bronze	Engineered polymer, bronze	Engineered polymer, bronze	Engineered polymer, bronze	Engineered polymer, bronze	Engineered polymer, bronze

DIMENSIONS

M25, M35, M55, M70 Bronze

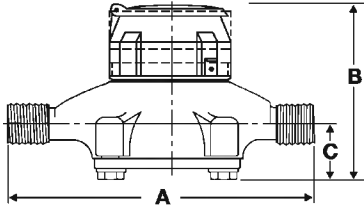

Meter Size	Model	A Laying Length	B Height w/Reg.	C Centerline Base	Width	Approx. Shipping Weight
5/8 in. (15 mm)	25	7-1/2 in. (190 mm)	4-15/16 in. (125 mm)	1-11/16 in. (42 mm)	4-1/4 in. (108 mm)	4-1/2 lb (2 kg)
5/8 in. x 3/4 in. (15 mm)		7-1/2 in. (190 mm)	4-15/16 in. (125 mm)	1-11/16 in. (42 mm)	4-1/4 in. (108 mm)	4-1/2 lb (2 kg)
3/4 in. (20 mm)	35	7-1/2 in. (190 mm)	5-1/4 in. (133 mm)	1-5/8 in. (41 mm)	5 in. (127 mm)	5-1/2 lb (2.5 kg)
3/4 in. (20 mm)		9 in. (229 mm)	5-1/4 in. (133 mm)	1-5/8 in. (41 mm)	5 in. (127 mm)	5-3/4 lb (2.6 kg)
3/4 in. x 1 in. (20 mm)		9 in. (229 mm)	5-1/4 in. (133 mm)	1-5/8 in. (41 mm)	5 in. (127 mm)	6 lb (2.7 kg)
1 in. (25 mm)	55	10-3/4 in. (273 mm)	6 in. (152 mm)	2-1/32 in. (52 mm)	6-1/4 in. (159 mm)	8-3/4 lb (3.9 kg)
1 in. (25 mm)	70	10-3/4 in. (273 mm)	6-1/2 in. (165 mm)	2-5/16 in. (59 mm)	7-3/4 in. (197 mm)	11-1/2 lb (5.2 kg)

M25 Polymer

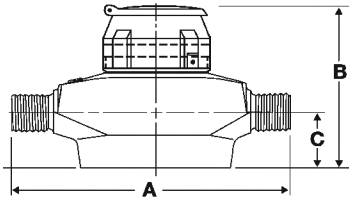

Meter Size	Model	A Laying Length	B Height w/Reg.	C Centerline Base	Width	Approx. Shipping Weight
5/8 in. (15 mm)	25	7-1/2 in. (190 mm)	5-1/16 in. (128 mm)	1-3/4 in. (44 mm)	4-13/16 in. (122 mm)	2-1/2 lb (1 kg)
5/8 x 3/4 in. (15 mm)		7-1/2 in. (190 mm)	5-1/16 in. (128 mm)	1-3/4 in. (44 mm)	4-13/16 in. (122 mm)	2-1/2 lb (1 kg)
3/4 in. (20 mm)		9 in. (229 mm)	5-1/16 in. (128 mm)	1-3/4 in. (44 mm)	4-13/16 in. (122 mm)	3 lb (1.4 kg)

M120, M170 Bronze

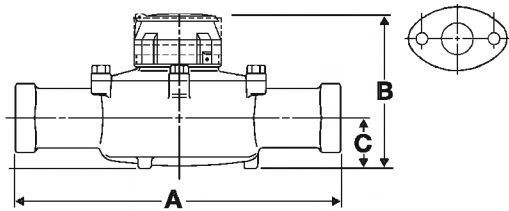

Meter Size	Meter Model	A Laying Length	B Height w/Reg.	C Centerline Base	Width	Approx. Shipping Weight
1-1/2 in. (40 mm)	120 EL, Hex 120 EL, TP	12-5/8 in. (321 mm)	7 in. (178 mm)	2-3/8 in. (60 mm)	8-3/4 in. (222 mm)	19 lb (8.6 kg)
1-1/2 in. (40 mm)	120 ELL 120 ELL, TP	13 in. (330 mm)	7 in. (178 mm)	2-3/8 in. (60 mm)	8-3/4 in. (222 mm)	19 lb (8.6 kg)
2 in. (50 mm)	170 EL, Hex 170 EL, TP	15-1/4 in. (387 mm)	8 in. (203 mm)	2-7/8 in. (73 mm)	9-1/2 in. (241 mm)	30 lb (13.6 kg)
2 in. (50 mm)	170 ELL 170 ELL, TP	17 in. (432 mm)	8 in. (203 mm)	2-7/8 in. (73 mm)	9-1/2 in. (241 mm)	30 lb (13.6 kg)

EL = Elliptical

ELL = Elliptical Long

Hex = Hexagon, 1-1/2...11-1/2 in. NPT Thread

TP=Test Plug 1 in.

SPECIFICATIONS

M25, M35, M55, M70 Bronze

Model	Model 25 Bronze	Model 25 Bronze	Model 35 Bronze	Model 55 Bronze	Model 70 Bronze
Size Designation	5/8 in.	5/8 × 3/4 in.	3/4 in.	1 in.	1 in.
Typical Operating Range (100% ± 1.5%)	0.5...25 gpm (0.11...5.7 m ³ /hr)	0.5...25 gpm (0.11...5.7 m ³ /hr)	0.75...35 gpm (0.17...7.9 m ³ /hr)	1...55 gpm (0.23...12.5 m ³ /hr)	1.25...70 gpm (0.28...16 m ³ /hr)
Maximum Continuous Operation	15 gpm (3.4 m ³ /hr)	15 gpm (3.4 m ³ /hr)	25 gpm (5.7 m ³ /hr)	40 gpm (9.1 m ³ /hr)	50 gpm (11.3 m ³ /hr)
Pressure Loss at Maximum Continuous Operation	3.5 psi @ 15 gpm (0.24 bar @ 3.4 m ³ /hr)	2.8 psi @ 15 gpm (0.19 bar @ 3.4 m ³ /hr)	5 psi @ 25 gpm (0.37 bar @ 5.7 m ³ /hr)	3.4 psi @ 40 gpm (0.23 bar @ 9.1 m ³ /hr)	6.5 psi @ 50 gpm (0.45 bar @ 11.3 m ³ /hr)
Maximum Operating Pressure	150 psi (10 bar)	150 psi (10 bar)	150 psi (10 bar)	150 psi (10 bar)	150 psi (10 bar)
Meter Connections	Available in NL bronze and engineered polymer to fit spud thread bore diameter sizes:				
	5/8 in. (DN 15 mm)	3/4 in. (DN 15 mm)	3/4 in. (DN 20 mm)	1 in. (DN 25 mm)	1 in. (DN 25 mm)

M25 Polymer

Model	Model 25 Polymer	Model 25 Polymer	Model 25 Polymer
Size Designation	5/8 in.	5/8 × 3/4 in.	3/4 in.
Typical Operating Range (100% ± 1.5%)	1/2...25 gpm (0.11...5.7 m ³ /hr)	1/2...25 gpm (0.11...5.7 m ³ /hr)	1/2...30 gpm (1.0...6.8 m ³ /hr)
Maximum Continuous Operation	15 gpm (3.4 m ³ /hr)	15 gpm (3.4 m ³ /hr)	15 gpm (3.4 m ³ /hr)
Pressure Loss at Maximum Continuous Operation	4.2 psi at 15 gpm (0.29 bar at 3.4 m ³ /hr)	2.8 psi at 15 gpm (0.19 bar at 3.4 m ³ /hr)	2.8 psi at 15 gpm (0.19 bar at 3.4 m ³ /hr)
Maximum Operating Pressure	150 psi (10 bar)	150 psi (10 bar)	150 psi (10 bar)
Meter Connections	Available in NL bronze and engineered polymer to fit spud thread bore diameter sizes:		
	5/8 in. (DN 15 mm)	3/4 in. (DN 15 mm)	3/4 in. (DN 15 mm)

M120, M170 Bronze

Model	Model 120 Bronze	Model 170 Bronze
Size Designation	1-1/2 in.	2 in.
Typical Operating Range (100% ± 1.5%)	2.5...120 gpm (0.57...27 m ³ /hr)	2.5...170 gpm (0.57...39 m ³ /hr)
Maximum Continuous Operation	80 gpm (18 m ³ /hr)	100 gpm (23 m ³ /hr)
Pressure Loss at Maximum Continuous Operation	4.8 psi at 80 gpm (0.33 bar at 18 m ³ /hr)	3.3 psi at 100 gpm (0.23 bar at 23 m ³ /hr)
Maximum Operating Pressure	150 psi (10 bar)	150 psi (10 bar)
Meter Connections	1-1/2 in. AWWA two-bolt elliptical flange, drilled or 1-1/2...11-1/2 NPT internal pipe threads	2 in. AWWA two-bolt elliptical flange, drilled or 2...11-1/2 NPT internal pipe threads
Test Plugs	Optional 1 in. NPT test plug (TP)	Optional 1 in. NPT test plug (TP)

PRESSURE LOSS CHARTS

Bronze Meters, Sizes 5/8... 1 inch

Rate of Flow in Gallons Per Minute

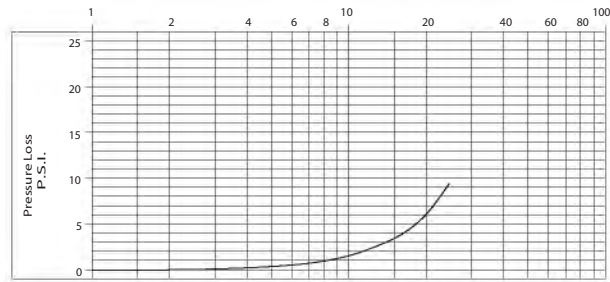

Model 25 5/8 in.

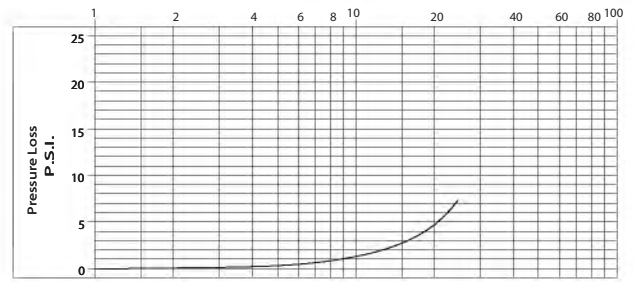

Model 25 5/8 x 3/4 in.

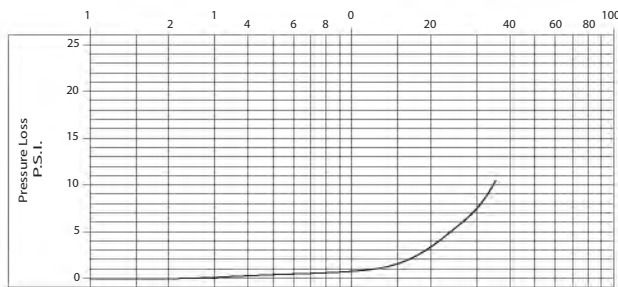

Model 35 3/4 in.

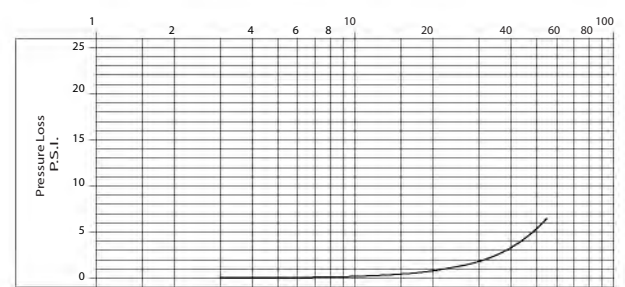

Model 55 1 in.

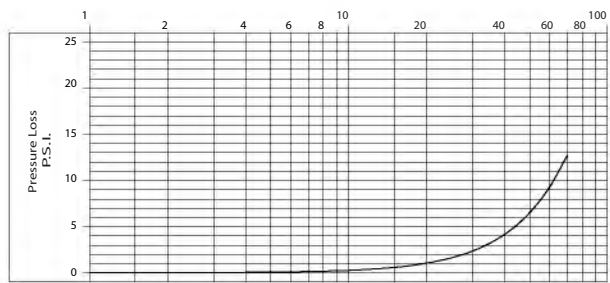

Model 70 1 in.

Polymer Meters, Sizes 5/8...3/4 inch

Rate of Flow in Gallons Per Minute

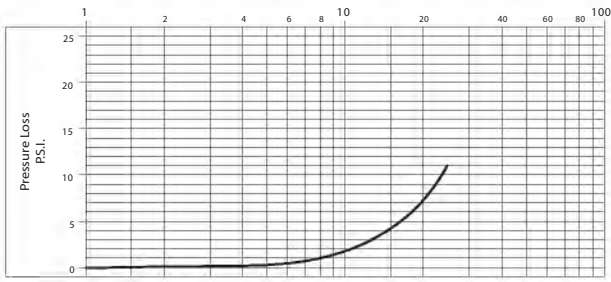

Model 25 Polymer 5/8 in.

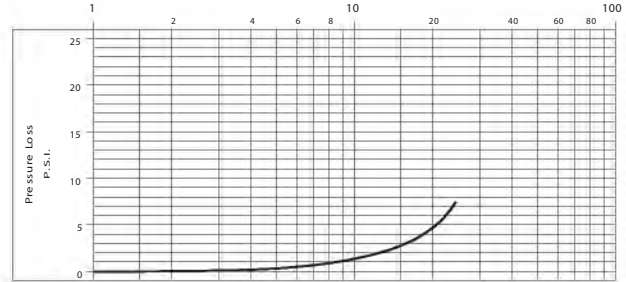

Model 25 Polymer 5/8 x 3/4 in.

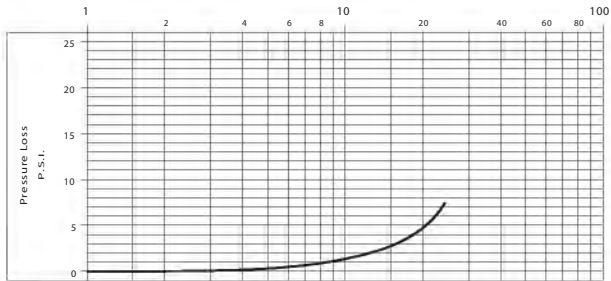

Model 25 Polymer 3/4 in.

Bronze Meters, Sizes 1-1/2 and 2 inch

Rate of Flow in Gallons Per Minute

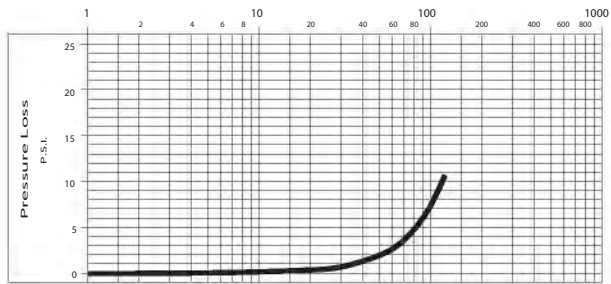

Model 120 1-1/2 in.

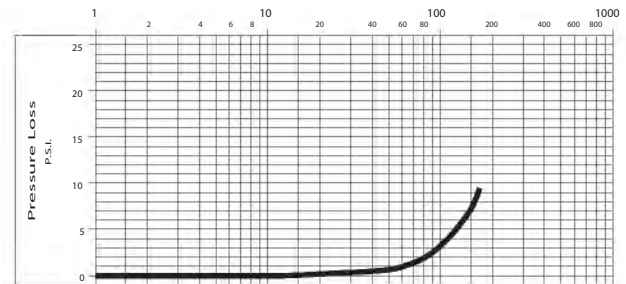

Model 170 2 in.

INTENTIONAL BLANK PAGE

Control. Manage. Optimize.

Recordall is a registered trademark of Badger Meter, Inc. Other trademarks appearing in this document are the property of their respective entities. Due to continuous research, product improvements and enhancements, Badger Meter reserves the right to change product or system specifications without notice, except to the extent an outstanding contractual obligation exists. © 2021 Badger Meter, Inc. All rights reserved.



E-Series® Ultrasonic Meter

Cold Water Engineered Polymer Meter, 5/8, 5/8 x 3/4, 3/4, and 1 inch

DESCRIPTION

The E-Series® Ultrasonic meter uses solid-state technology in a compact, totally encapsulated, weatherproof, and UV-resistant housing, suitable for residential and commercial applications. Electronic metering provides information—such as rate of flow and reverse flow indication—and data not typically available through traditional, mechanical meters and registers. Electronic metering eliminates measurement errors due to sand, suspended particles and pressure fluctuations.

The Ultrasonic 5/8, 5/8 × 3/4, 3/4, and 1 inch meters feature:

- Minimum extended low-flow rate lower than typical positive displacement meters.
- Simplified one-piece electronic meter and register that are integral to the meter body and virtually maintenance free.
- Sealed, non-removable, tamper-protected meter and register.
- Easy-to-read, 9-digit LCD display presents consumption, rate of flow, reverse-flow indication, and alarms.
- High resolution industry standard ASCII encoder protocol.

The Ultrasonic meter is available with an in-line connector for easy connection and installation to AMR/AMI endpoints. It is also available with a flying lead for field splice connection.

APPLICATIONS

Use the Ultrasonic meter for measuring potable cold water in residential, commercial and industrial services. The meter is also ideal for non-potable, irrigation water applications or less than optimum water conditions where small particles exist.

E-Series Ultrasonic meters meet and exceed ANSI/AWWA C715 standards. The meters comply with the lead-free provisions of the Safe Drinking Water Act, are certified to NSF/ANSI Standards 61 and 372 and carry the NSF-61 mark on the housing.

OPERATION & PERFORMANCE

As water flows into the measuring tube, ultrasonic signals are sent consecutively in forward and reverse directions of flow. Velocity is then determined by measuring the time difference between the measurement in the forward and reverse directions. Total volume is calculated from the measured flow velocity using water temperature and pipe diameter. The LCD display shows total volume and alarm conditions and can toggle to display rate of flow.



In the normal temperature range of 45...122° F (7...50° C), the Ultrasonic “new meter” consumption measurement is accurate to:

- ±1.5% over the normal flow range
- ±3.0% from the extended low flow range to the minimum flow value

CONSTRUCTION

E-Series Ultrasonic meters feature an engineered polymer, lead-free meter housing, an engineered polymer and stainless steel metering insert, a meter-control circuit board with associated wiring, LCD, and battery. Wetted elements are limited to the pressure vessel, polymer/stainless steel metering insert and the transducers. The electronic components are housed and fully potted within a molded, engineered polymer enclosure, which is permanently attached to the meter housing. The transducers extend through the polymer housing and are sealed by O-rings.

The metering insert holds the stainless steel ultrasonic reflectors in the center of the flow area, enabling turbulence-free water flow through the tube and around the ultrasonic signal reflectors. The metering insert’s patented design virtually eliminates chemical buildup on the reflectors, ensuring long-term metering accuracy.

METER INSTALLATION

The meter is completely submersible and can be installed using horizontal or vertical piping, with flow in the up direction. The meter will not measure flow when an “empty pipe” condition is experienced. An empty pipe is defined as a condition when the flow sensors are not fully submerged.

SPECIFICATIONS

E-Series Ultrasonic Meter Size	5/8 in. (15 mm)	5/8 x 3/4 in. (15 mm)	3/4 in. (20 mm)	1 in. (25 mm)
Normal Test Flow Limits	0.1...25 gpm (0.02...5.7 m ³ /hr)	0.1...25 gpm (0.02...5.7 m ³ /hr)	0.1...32 gpm (0.02...7.3 m ³ /hr)	0.4...55 gpm (0.09...12.5 m ³ /hr)
Minimum Test Flow Limits	0.05 gpm (0.01 m ³ /hr)	0.05 gpm (0.01 m ³ /hr)	0.05 gpm (0.01 m ³ /hr)	0.25 gpm (0.06 m ³ /hr)
Safe Maximum Operating Condition (SMOC)	25 gpm (5.7 m ³ /hr)	25 gpm (5.7 m ³ /hr)	32 gpm (7.3 m ³ /hr)	55 gpm (12.5 m ³ /hr)
Typical Pressure Loss	4.3 psi at 15 gpm (0.3 bar @ 3.4 m ³ /hr)	2.3 psi at 15 gpm (0.16 bar @ 3.4 m ³ /hr)	2.0 psi at 15 gpm (0.14 bar @ 3.4 m ³ /hr)	1.8 psi at 25 gpm (0.12 bar @ 5.7 m ³ /hr)
Reverse Flow - Maximum Rate	4.0 gpm (0.9 m ³ /hr)	4.0 gpm (0.9 m ³ /hr)	4.0 gpm (0.9 m ³ /hr)	9.0 gpm (2.0 m ³ /hr)
Operating Performance	In the normal temperature range of 45...122° F (7...50° C), new meter consumption measurement is accurate to: <ul style="list-style-type: none"> • ± 1.5% over the normal flow range • ± 3.0% from the extended low flow range to the minimum flow value 			
Storage Temperature	- 40...140° F (- 40...60° C)			
Maximum Ambient Storage (Storage for One Hour)	150° F (66° C)			
Measured-Fluid Temperature Range	34...140° F (1°...60° C)			
Humidity	0...100% condensing; meter is capable of operating in fully submerged environments			
Maximum Operating Pressure of Meter Housing	175 psi (12 bar)			
Register Type	Straight reading, permanently sealed electronic LCD; digits are 0.28 in. (7 mm) high			
Register Display	<ul style="list-style-type: none"> • Consumption (up to nine digits) • Rate of flow • Alarms • Unit of measure factory programmed for gallons, cubic feet and cubic meters 			
Register Capacity	<ul style="list-style-type: none"> • 10,000,000 gallons • 1,000,000 cubic feet • 100,000 cubic meters 			
Totalization Display Resolution	<ul style="list-style-type: none"> • Gallons: 0.XX • Cubic feet: 0.XXX • Cubic meters: 0.XXXX 			
Battery	3.6-volt lithium thionyl chloride; battery is fully encapsulated within the register housing and is not replaceable; 20-year battery life			

MATERIALS

Meter Housing	Engineered polymer
Measuring Element	Pair of ultrasonic sensors located in the flow tube
Register Housing & Lid	Engineered polymer
Metering Insert	Engineered polymer & stainless steel
Transducers	Piezo-ceramic device with wetted surface of stainless CrNiMo

PHYSICAL DIMENSIONS

E-Series Ultrasonic Meter Size	5/8 in. (15 mm)	5/8 (15 mm) x 3/4 in. (20 mm)	3/4 in. (20 mm)	1 in. (25 mm)
Size Designation X Lay Length	5/8 x 7-1/2 in. (16 x 191 mm)	5/8 x 3/4 x 7-1/2 in. (16 x 19 x 191 mm)	3/4 x 7-1/2 in. or 3/4 x 9 in. (19 x 191 mm or 19 x 229 mm)	1 x 10-3/4 in. (25 x 273 mm)
Weight (without AMR)	1.60 lb (0.73 kg)	1.58 lb (0.72 kg)	3/4 x 7-1/2 in.: 1.58 lb or 3/4 x 9 in.: 1.64 lb (19 x 191 mm: 0.72 kg or 19 x 229 mm: 0.74 kg)	2.3 lb (1.04 kg)
See illustration below for Measurement Designations.				
Length (A)	7.5 in. (191 mm)	7.5 in. (191 mm)	7.5 in. or 8.85 in. (191 mm or 225 mm)	10.75 in. (273 mm)
Height (B)	2.46 in. (62 mm)	2.46 in. (62 mm)	2.46 in. (62 mm)	2.66 in. (68 mm)
Height (C)	3.27 in. (83 mm)	3.23 in. (82 mm)	3.23 in. (82 mm)	3.62 in. (92 mm)
Width (D)	3.90 in. (99 mm)	3.90 in. (99 mm)	3.90 in. (99 mm)	3.90 in. (99 mm)
Bore Size	5/8 in. (15 mm)	3/4 in. (19 mm)	3/4 in. (19 mm)	1 in. (25 mm)
Coupling Nut & Spud Thread	3/4 in. x 14 NPSM	1 in. x 11-1/2 NPSM	1 in. x 11-1/2 NPSM	1-1/4 in. x 11-1/2 NPSM
Tailpiece Pipe Thread (NPT)	1/2 in.	3/4 in.	3/4 in.	1 in.
Service Pipe Thread (NPT)	1/2 in.	3/4 in.	3/4 in.	1 in.

MEASUREMENT DESIGNATIONS

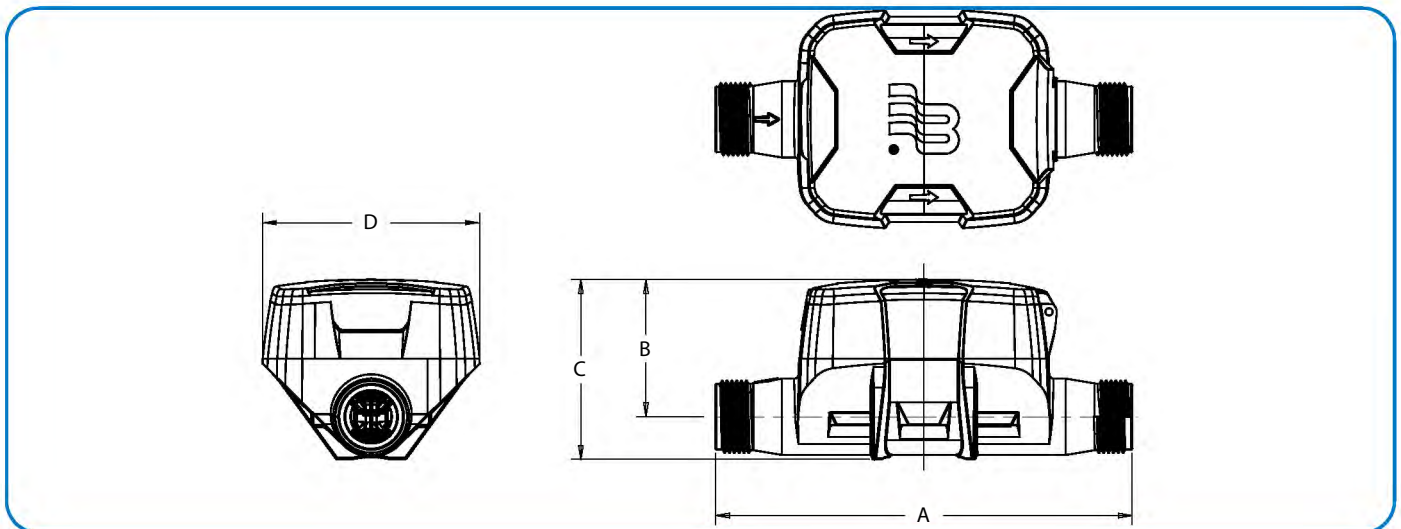

PRESSURE LOSS CHART

Rate of Flow in gallons per minute (gpm)

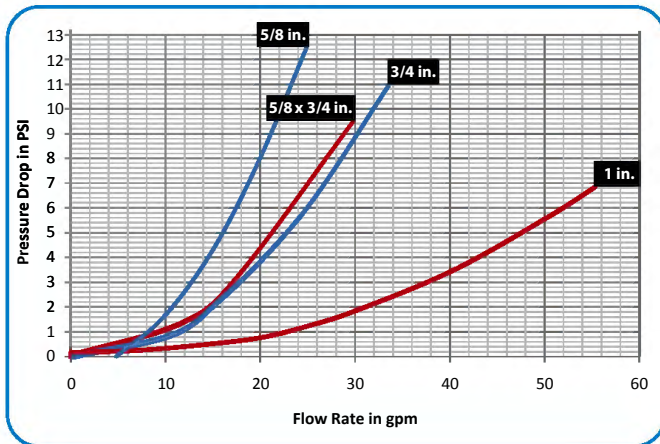

ACCURACY CHARTS

Rate of Flow in gallons per minute (gpm)

5/8 IN. METER

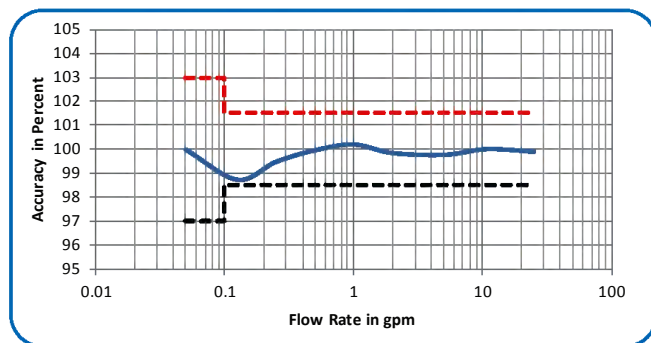

5/8 x 3/4 IN. METER

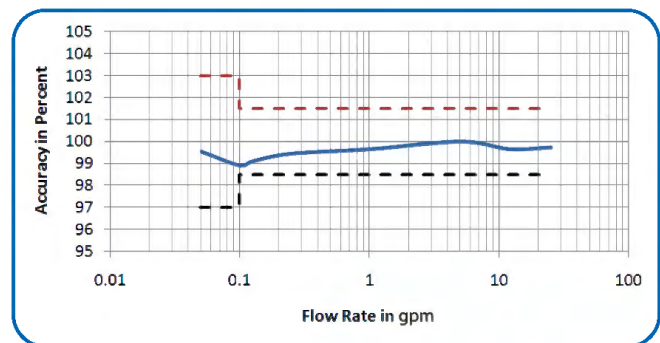

3/4 IN. METER

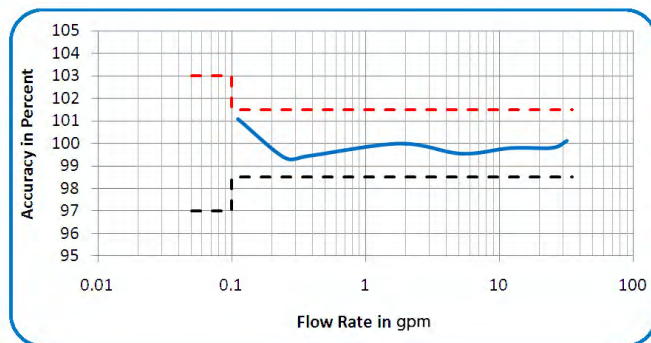

1 IN. METER

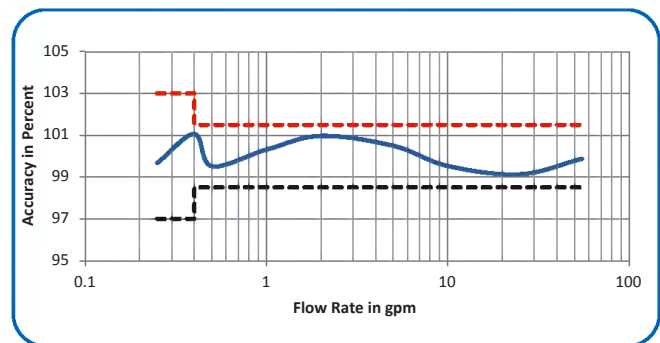

SMART WATER IS BADGER METER

E-Series is a registered trademark of Badger Meter, Inc. Other trademarks appearing in this document are the property of their respective entities.

Due to continuous research, product improvements and enhancements, Badger Meter reserves the right to change product or system specifications without notice, except to the extent an outstanding contractual obligation exists. © 2020 Badger Meter, Inc. All rights reserved.



Badger Meter

Recordall® Turbo Series Meters

Models 160 (1-1/2 in.), 200 (2 in.), 450 (3 in.), 1000 (4 in.), 2000 (6 in.), 3500 (8 in.), 5500 (10 in.) and 6200 (12 in.)
NSF/ANSI Standards 61 and 372 Certified

DESCRIPTION

Recordall Turbo Series meters meet or exceed the most recent revision of AWWA Standard C701 Class II Standards and are available in a lead-free bronze alloy for sizes 1-1/2 in. through 10 in. and cast iron for 12 in. meters. Turbo Series meters comply with the lead-free provisions of the Safe Drinking Water Act. Sizes 1-1/2 in. through 10 in. meters are also certified to NSF/ANSI Standards 61 and 372 (Trade Designation: Turbo Series LL-NS) and carry the NSF-61 mark on the housing. All components of the lead-free alloy meter (housing, measuring element, seals and so on) comprise the certified system.

Models 160 through 6200 are designed for 1-1/2 in. through 12 in. applications. These meters feature:

- Direct coupled turbine based on an exclusive “floating rotor” design that reduces bearing friction—and associated wear and tear.
- Low pressure loss for improved system efficiency.
- Exceptional registration accuracy across low flow rate, normal operating flow rate and maximum continuous operation flow.
- Permanently sealed, tamper-resistant register or encoder.
- Integral strainer helps protect your system from damaging debris and related downtime. Integral strainer is standard on 1-1/2 in. meter, and optional on 2 in. through 4 in. meters.
- Meters and encoders are compatible with Badger Meter AMR/AMI meter reading systems and other approved reading technologies.

Applications: Recordall Turbo Series meters are designed for cold water, commercial and industrial applications where flows are consistent medium to high flows. Applications include hotels, apartment buildings, irrigations centers and manufacturing and processing plants. Turbo Series meters help reduce day-to-day maintenance costs while delivering accurate and efficient performance.

Operation & Performance: Direct magnetic drive is achieved when the magnet carrier is driven by a gear train coupled to the rotor. The gear train consists of two sets of gears connected by a vertical transmission shaft. One gear set is at the magnet carrier, the other is a worm gear set at the rotor shaft. When water flows into the Turbo Series meter measuring element, it contacts the multi-vaned rotor. The resulting rotor rotation is then transmitted by magnetic coupling to a sealed register or encoder. The direct magnetic drive is built to provide a reliable meter-to-registration coupling.



Tamper-Proof Features: Unauthorized removal of the register or encoder is inhibited by the option of a tamper detection seal wire screw, TORX® tamper-resistant seal screw or the proprietary tamper-resistant keyed seal screw. Each can be installed at the meter site or at the factory.

Construction: The Recordall Turbo Series meter is constructed in compliance with ANSI and AWWA C701 standards. It consists of the following basic components: meter housing, interchangeable, unitized measuring element and permanently sealed direct reading registers or encoders.

The measuring element consists of the transmission coupling, rotor, inlet and outlet straightening vanes with nose cones, and calibration ring assembly. The unique inlet and outlet straightening vanes minimize swirl from piping arrangements upstream as well as downstream.

A strainer is recommended to help ensure optimal flow conditioning and protection for the measuring element. The integral strainer is standard on the 1-1/2 in. meter and an available option on the 2 in. through 4 in. meters. The stainless steel strainer is built into the inlet end and includes a removable cover plate to permit easy access for routine cleaning. External strainers are available in sizes 2 in. through 12 in.

To simplify maintenance, the registers or encoders and measuring elements can be removed without removing the meter housing. Interchangeability of certain parts between meters also minimizes spare parts inventory investment.

Meter Installation: The meter is designed for installations where flow is in one direction only. Companion flanges for installation of meters on various pipe types and sizes are available in cast iron or NL bronze as an option. See the *Recordall Turbo Series Meters User Manual* available at www.badgermeter.com for specific instructions.

SPECIFICATIONS

Turbo Series Model	160 1-1/2 in. (40 mm)	200 2 in. (50 mm)	450 3 in. (80 mm)	1000 4 in. (100 mm)	2000 6 in. (150 mm)	3500 8 in. (200 mm)	5500 10 in. (250 mm)	6200 12 in. (300 mm)
Meter Flanges AWWA 125 Pound Class	Elliptical	Elliptical or Round	Round	Round	Round	Round	Round	Round AWWA 125 lb class
Typical Operating Range (100% ± 1.5%)	4...200 gpm (0.9...45.4 m ³ /h)	4...310 gpm (0.9...70.4 m ³ /h)	5...550 gpm (1.1...124.9 m ³ /h)	10...1250 gpm (2.3...284 m ³ /hr)	20...2500 gpm (4.5...568 m ³ /h)	30...4500 gpm (6.8...1022 m ³ /h)	50...7000 gpm (11.4...1590 m ³ /h)	90...8800 gpm (20.5...1998 m ³ /h)
Typical Low Flow (95% min.)	2.5 gpm (0.6 m ³ /h)	2.5 gpm (0.6 m ³ /h)	4 gpm (0.9 m ³ /h)	6 gpm (1.4 m ³ /h)	12 gpm (2.7 m ³ /h)	20 gpm (4.5 m ³ /h)	30 gpm (6.8 m ³ /h)	65 gpm (14.8 m ³ /h)
Max. Continuous Flow	160 gpm (36 m ³ /h)	200 gpm (45.4 m ³ /h)	450 gpm (102.2 m ³ /h)	1000 gpm (227.1 m ³ /h)	2000 gpm (454 m ³ /h)	3500 gpm (795 m ³ /h)	5500 gpm (1250 m ³ /h)	6200 gpm (1408 m ³ /h)
Maximum Intermittent Flow	200 gpm (45.4 m ³ /h)	310 gpm (70.4 m ³ /h)	550 gpm (124.9 m ³ /h)	1250 gpm (284 m ³ /h)	2500 gpm (568 m ³ /h)	4500 gpm (1022 m ³ /h)	7000 gpm (1590 m ³ /h)	8800 gpm (1988 m ³ /h)
Pressure Loss at Max. Continuous Flow	3.8 psi (0.26 bar)	3.1 psi (0.21 bar)	1.8 psi (0.12 bar)	7.3 psi (0.50 bar)	4.8 psi (0.33 bar)	2.5 psi (0.17 bar)	1.6 psi (0.11 bar)	0.8 psi (0.05 bar)
Pressure Loss at Max. Continuous Flow: With Integral Strainer	9.9 psi (0.68 bar)	8.3 psi (0.57 bar)	5 psi (0.43 bar)	17.8 psi (1.2 bar)	—			
Max. Operating Pressure	150 psi (10 bar)							
Max. Operating Temperature	120° F (49° C)							
Integral Strainer	Optional on 2 in. through 4 in. meters. Built into inlet end. Removable cover plate permits access to strainer for cleaning.				—			
Optional External Strainer	—	Available for Models 200, 450, 1000, 2000, 3500, 5500 and 6200.						
NPT Test Port	Standard with integral strainer; optional for other models.				Optional for Models 2000 and 3500.		—	

MATERIALS

Meter Housing	Lead-free alloy (EXCEPTION: Model 6200 meter housing is blue epoxy-coated cast iron)
Turbo Head	Lead-free alloy
Nose Cone & Straightening Vanes	Thermoplastic
Rotor	Thermoplastic
Rotor Radial Bearings	Lubricated thermoplastic
Rotor Thruster Bearing	Sapphire jewels
Rotor Bearing Pivots	Passivated 316 stainless steel
Calibration Mechanism	Stainless steel & thermoplastic
Magnet	Ceramic
Trim	Stainless steel
Register Housing & Cover	Thermoplastic or bronze
Integral Strainer & Trim	Stainless steel

REGISTERS / ENCODERS

Standard—Sweep-Hand Registration

The standard register is a straight-reading, permanently sealed magnetic drive register. Dirt, moisture, tampering and lens fogging problems are eliminated. The register has a six-odometer wheel totalization display, 360° test circle with center sweep hand, and flow finder to detect leaks. Register gearing is made of self-lubricating engineered polymer, which minimizes friction and provides long life. The multi-position register simplifies meter installation and reading. The register capacity for the 1-1/2 in., 2 in., 3 in. and 4 in. meters is 100,000,000 gallons (10,000,000 ft³, 1,000,000 m³). The register capacity for the 6 in., 8 in., and 10 in. meters is 1,000,000,000 gallons (100,000,000 ft³, 10,000,000 m³). The high-flow register capacity for the 12 in. meter is 10,000,000,000 gallons (1,000,000,000 ft³, 10,000,000 m³).

Registers for 1-1/2 in., 2 in., 3 in. and 4 in. Meters

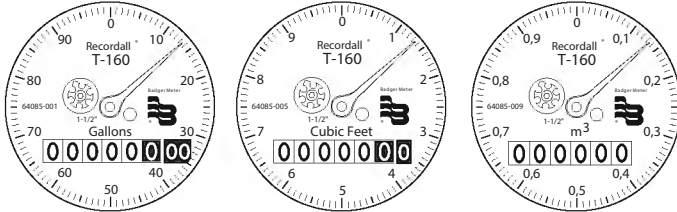

Sweep Hand Revolution

Meter Model	Gallon	Cubic Feet	Cubic Meter
160	100	10	1
200	100	10	1
450	100	10	1
1000	100	10	1

Registers for 6 in., 8 in. and 10 in. Meters

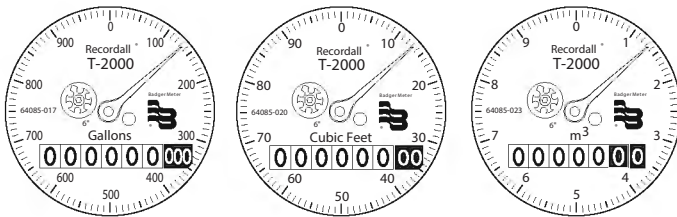

Sweep Hand Revolution

Meter Model	Gallon	Cubic Feet	Cubic Meter
2000	1000	100	10
3500	1000	100	10
5500	1000	100	10

Registers for 12 in. Meters

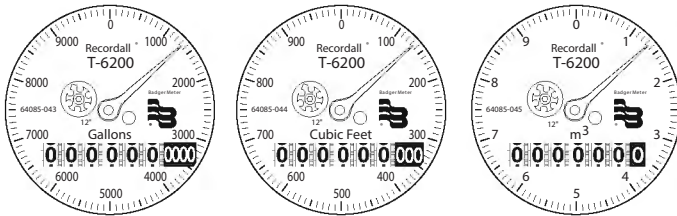

Sweep Hand Revolution

Meter Model	Gallon	Cubic Feet	Cubic Meter
6200	10000	1000	10

Optional—Encoders for AMR/AMI Reading Solutions

AMR/AMI solutions are available for all Recordall Disc Series meters. All reading options can be removed from the meter without disrupting water service. Badger Meter encoders provide years of reliable, accurate readings for a variety of applications and are also available pre-wired to Badger Meter approved AMR/AMI solutions. See details at www.badgermeter.com.

PHYSICAL DIMENSIONS OF METERS WITHOUT STRAINER

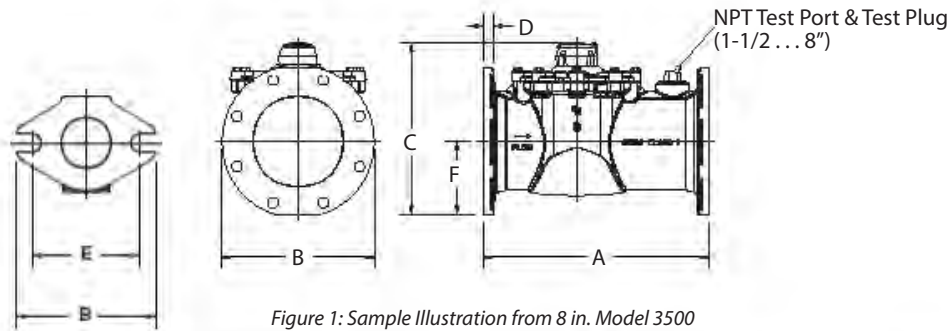

Figure 1: Sample Illustration from 8 in. Model 3500

Turbo Series Model	200	200	450	1000	2000	3500	5500	6200
Meter Flanges	2 in. Elliptical	2 in. Round	3 in. Round	4 in. Round	6 in. Round	8 in. Round	10 in. Round	12 in. Round
Meter & Pipe Size	2 in. (50 mm)	2 in. (50 mm)	3 in. (80 mm)	4 in. (100 mm)	6 in. (150 mm)	8 in. (200 mm)	10 in. (250 mm)	12 in. (300 mm)
Net Weight	14.9 lb (6.8 kg)	17.4 lb (7.9 kg)	31 lb (14.1 kg)	40 lb (18.1 kg)	77 lb (35 kg)	123 lb (55.7 kg)	210 lb (95.3 kg)	262 lb (118.8 kg)
Shipping Weight	16.4 lb (7.4 kg)	18.9 lb (8.6 kg)	34 lb (15.4 kg)	45 lb (20.4 kg)	89 lb (40.4 kg)	147 lb (66.6 kg)	235 lb (106.6 kg)	286 lb (129.7 kg)
Qty. of Bolts	2	4	4	8	8	8	12	12
NPT Test Port (optional)	1-1/2 in. (40 mm)	1-1/2 in. (40 mm)	2 in. (50 mm)	2 in. (50 mm)	2 in. (50 mm)	2 in. (50 mm)	—	—
Length (A)	10 in. (254 mm)	10 in. (254 mm)	12 in. (305 mm)	14 in. (356 mm)	18 in. (457 mm)	20 in. (508 mm)	26 in. (660.4 mm)	19-11/16 in. (500 mm)
Width (B)	5-27/32 in. (148 mm)	6 in. (152 mm)	7-1/2 in. (191 mm)	9 in. (229 mm)	11 in. (280 mm)	13-1/2 in. (343 mm)	16 in. (406.4 mm)	19 in. (482 mm)
Height (C)	6-1/2 in. (165 mm)	7-3/32 in. (180 mm)	8-11/16 in. (220 mm)	9-21/32 in. (245 mm)	13-5/16 in. (338 mm)	15-3/16 in. (385 mm)	17-15/32 in. (443 mm)	19-11/16 in. (500 mm)
Flange (D)	25/32 in. (20 mm)	5/8 in. (16 mm)	3/4 in. (19 mm)	13/16 in. (21 mm)	7/8 in. (22 mm)	1 in. (25 mm)	1-1/16 in. (27 mm)	1.26 in. (32 mm)
Bolt Circle (E)	4-1/2 in. (114 mm)	4-3/4 in. (121 mm)	6 in. (152 mm)	7-1/2 in. (191 mm)	9-1/2 in. (241 mm)	11-3/4 in. (298 mm)	14-1/4 in. (362 mm)	17 in. (432 mm)
Centerline (F)	2-1/16 in. (52 mm)	2-5/8 in. (67 mm)	3-11/32 in. (85 mm)	4-5/16 in. (109 mm)	5-1/4 in. (133 mm)	6-3/8 in. (162 mm)	7-7/8 in. (199.4 mm)	8-7/8 in. (226 mm)

PHYSICAL DIMENSIONS OF METERS WITH INTEGRAL STRAINER

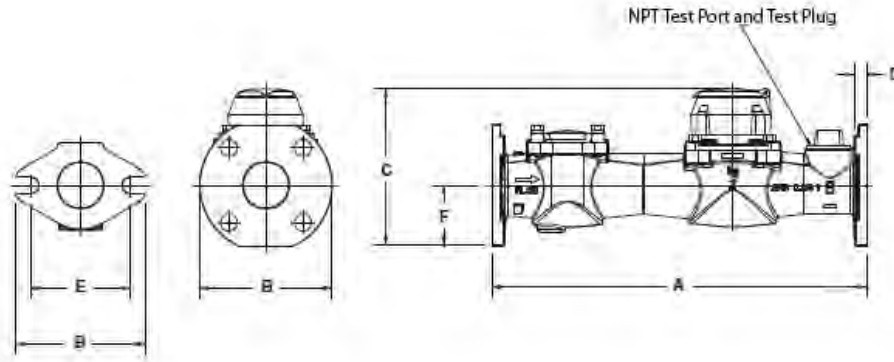
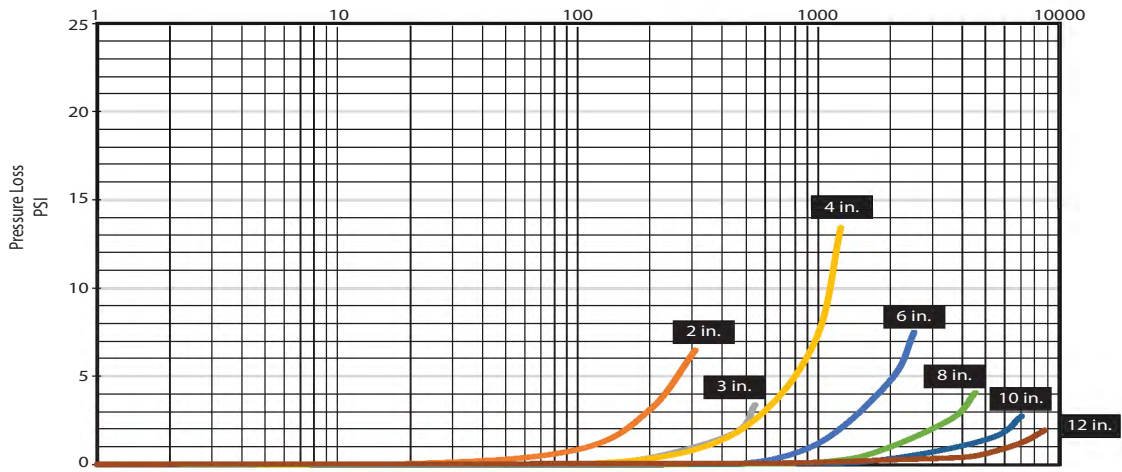

Figure 2: Physical dimensions

Turbo Series Model	160	200	200	450	1000
Meter Flanges	Elliptical	Elliptical	Round	Round	Round
Meter & Pipe Size	1-1/2 in. (40 mm)	2 in. (50 mm)	2 in. (50 mm)	3 in. (80 mm)	4 in. (100 mm)
Net Weight	14.3 lb (6.5 kg)	24 lb (11 kg)	26 lb (12 kg)	49 lb (22 kg)	60 lb (27.22 kg)
Shipping Weight	16.8 lb (7.6 kg)	28 lb (13 kg)	30 lb (14 kg)	55 lb (25 kg)	70 lb (31.75 kg)
Number of Bolts	2	2	4	4	8
NPT Test Port (Standard)	1 in. (25.4 mm)	1-1/2 in. (40 mm)	1-1/2 in. (40 mm)	2 in. (50 mm)	2 in. (50 mm)
Length (A)	13 in. (330 mm)	17 in. (432 mm)	17 in. (432 mm)	19 in. (483 mm)	23 in. (584 mm)
Width (B)	5-7/32 in. (133 mm)	5-27/32 in. (148 mm)	6 in. (152 mm)	7-1/2 in. (191 mm)	9 in. (229 mm)
Height (C)	6-9/32 in. (159 mm)	6-1/2 in. (165 mm)	7-3/32 in. (180 mm)	8-15/16 in. (227 mm)	9-21/32 in. (245 mm)
Flange (D)	51/64 in. (20 mm)	27/32 in. (47 mm)	5/8 in. (16 mm)	27/32 in. (21 mm)	13/16 in. (21 mm)
Bolt Circle (E)	4 in. (102 mm)	4-1/2 in. (114 mm)	4-3/4 in. (121 mm)	6 in. (152 mm)	7-1/2 in. (191 mm)
Centerline (F)	1-27/32 in. (47 mm)	2-1/16 in. (52 mm)	2-5/8 in. (67 mm)	3-19/32 in. (91 mm)	4-5/16 in. (109 mm)

PRESSURE LOSS CHART FOR METERS WITHOUT STRAINER

Rate of flow in gallons per minute (gpm)



PRESSURE LOSS CHART FOR METERS WITH INTEGRAL STRAINER

Rate of flow in gallons per minute (gpm)

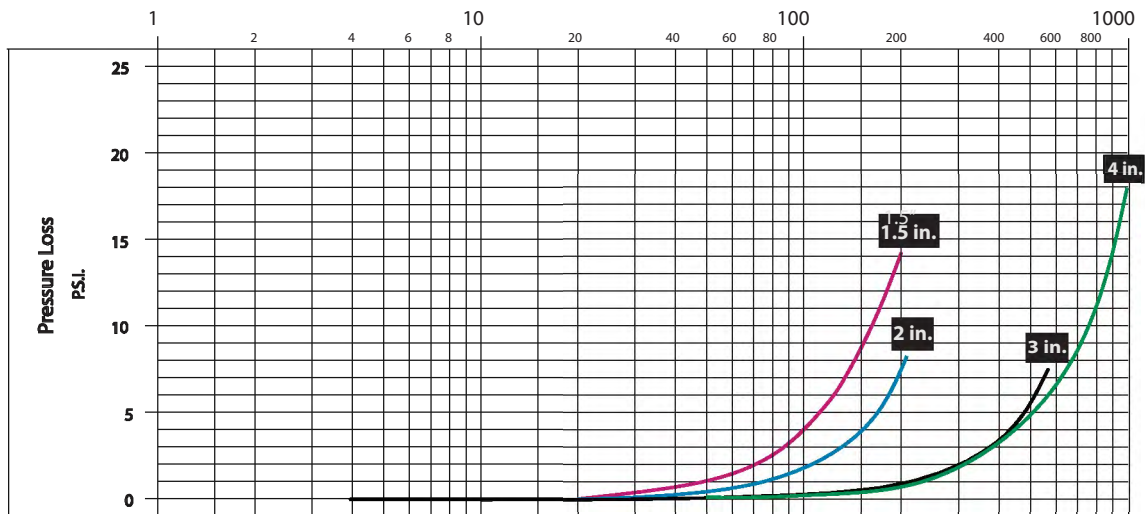

ACCURACY CHARTS FOR METERS WITHOUT STRAINER

Rate of flow in gallons per minute (gpm)

2 in. Meter

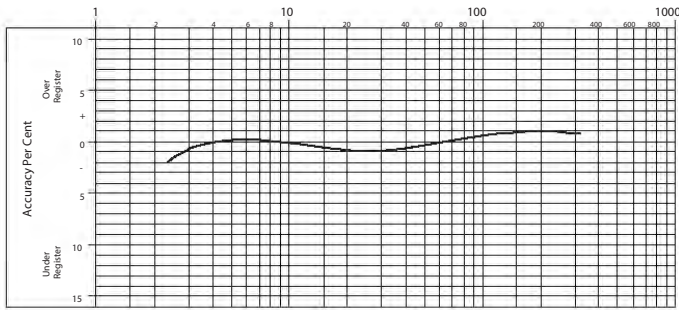

8 in. Meter

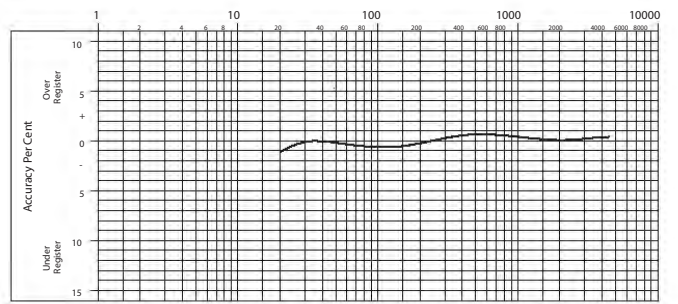

3 in. Meter

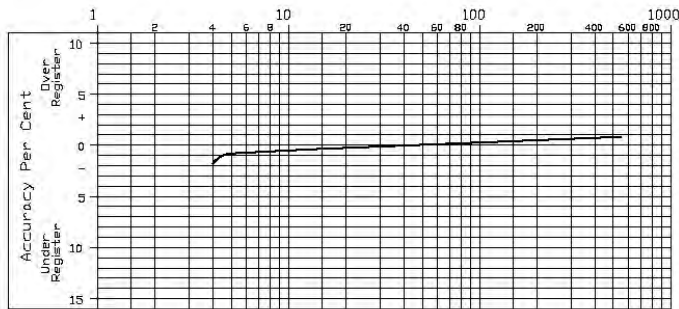

10 in. Meter

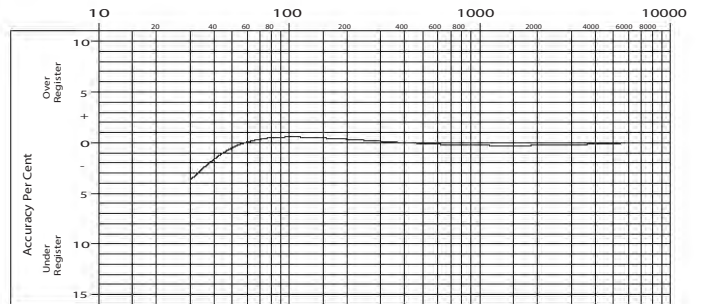

4 in. Meter

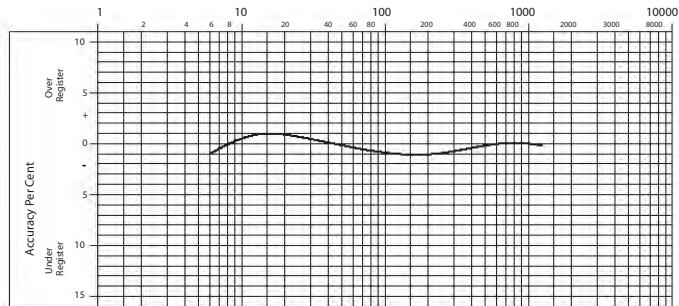

12 in. Meter

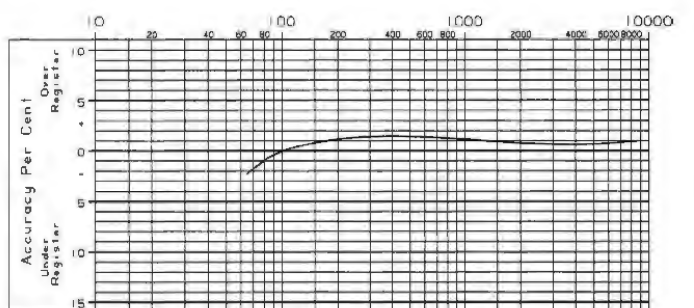

6 in. Meter

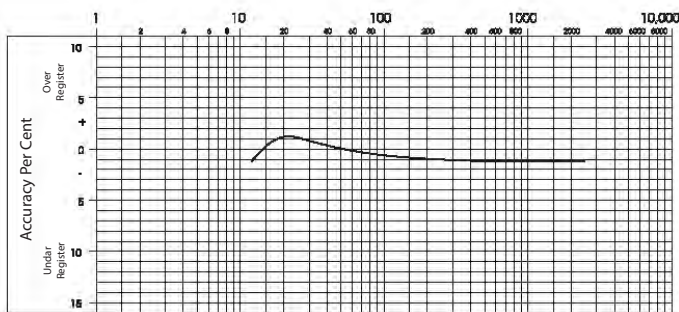

ACCURACY CHARTS FOR METERS WITH INTEGRAL STRAINER

Rate of flow in gallons per minute (gpm)

1-1/2 in. Meter

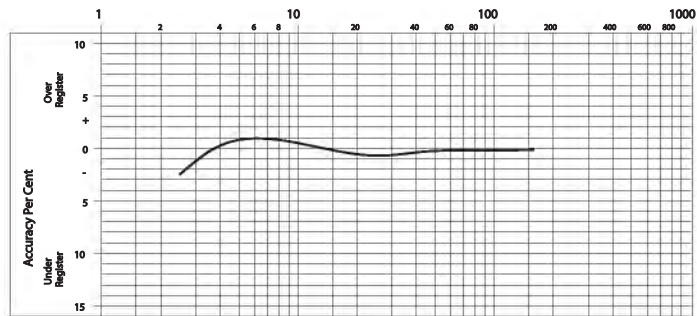

2 in. Meter

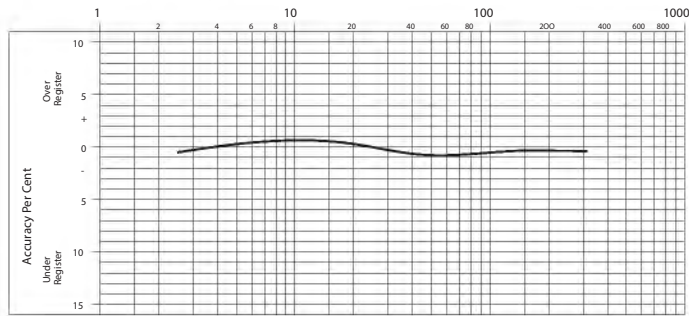

3 in. Meter

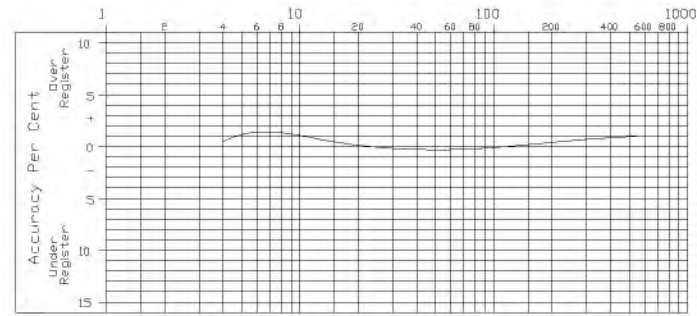

4 in. Meter

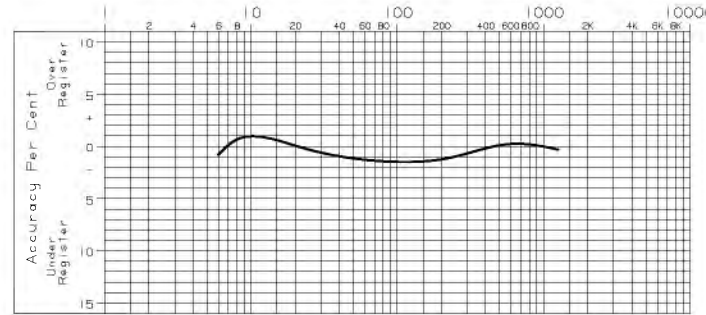

SMART WATER IS BADGER METER

RECORDALL is a registered trademark of Badger Meter, Inc. Other trademarks appearing in this document are the property of their respective entities. Due to continuous research, product improvements and enhancements, Badger Meter reserves the right to change product or system specifications without notice, except to the extent an outstanding contractual obligation exists. © 2020 Badger Meter, Inc. All rights reserved.



Badger Meter

Recordall® Compound Series Meter

Lead-Free Bronze Alloy, Sizes 2, 3, 4 & 6 inch
NSF/ANSI Standards 61 and 372 Certified

DESCRIPTION

The Recordall® Compound Series meters meet or exceed the most recent revision of AWWA Standard C702 and are available in a lead-free bronze alloy. The Compound Series meters comply with the lead-free provisions of the Safe Drinking Water Act, are certified to NSF/ANSI Standards 61 and 372 (Trade Designation: LL-NS) and carry the NSF-61 mark on the housing. All components of the lead-free bronze alloy meter (housing, measuring element, seals, and so on) comprise the certified system.

Badger Meter Recordall Compound Series meters combine two metering technologies in one innovative package. A positive displacement chamber measures low flow, while a turbine chamber records high flow.

Offered in four sizes, the Compound Series meter features:

- Patented design that eliminates the need for a trigger valve and maintains crossover accuracy.
- Permanently sealed, tamper-resistant register or encoder.
- Meters and encoders that are compatible with Badger Meter AMR/AMI systems and other approved reading technologies

Badger Meter ORION® and GALAXY® AMR/AMI meter reading systems are available for all Compound Series meters. Itron® ERT reading systems are also available. An optional summator can be provided as an integral part of the register assembly. All register options are removable from the meter without disrupting water service.

TAMPER-PROOF FEATURES

Unauthorized removal of the register or encoder is inhibited by the use of an optional tamper detection seal wire screw, TORX® tamper-resistant seal screw or the proprietary tamper-resistant keyed seal screw. Each can be installed at the meter site or at the factory.

APPLICATIONS

Use the Recordall Compound meter for measuring potable cold water in commercial and industrial applications where flow is in one direction only. The meter is an ideal choice for facilities that experience rapid and wide fluctuations in water demand, such as hospitals, universities, residential complexes and manufacturing or processing facilities.

OPERATION

At low flow rates, the Compound Series meter diverts water up through a bypass to the disc chamber. Leaving the chamber's outlet port, water flows beyond the turbine element and main valve. As the flow rate increases, a pressure differential is created that opens the main valve. The water then flows straight through the turbine chamber. In addition, a portion still flows through the disc chamber before exiting the meter.

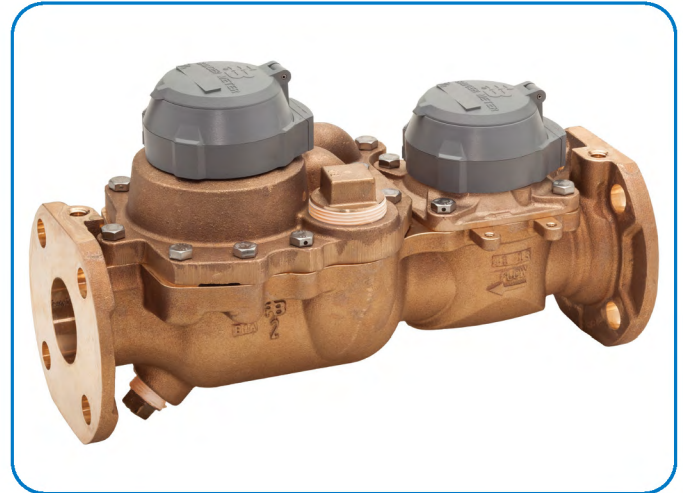

Rotor and disc movements are transmitted by magnetic drive couplings to individual register odometers. The direct magnetic drive provides a positive, reliable and dependable register coupling for straight-reading or remote reading options. The self-lubricating thermoplastic register gearing is designed to minimize friction and provide long life.

OPERATING PERFORMANCE

The Recordall Compound Series meets or exceeds registration accuracy for low, normal operating, maximum continuous operation, and changeover flow rates as specified in AWWA Standard C702.

CONSTRUCTION

The Recordall Compound Series meter's construction complies with ANSI and AWWA C702 standards. It consists of three basic components: meter housing, interchangeable measuring elements, and sealed direct reading registers. The measuring element consists of the disc measuring chamber, turbine head assembly, and high flow valve assembly. To simplify maintenance, the registers and measuring elements can be removed without removing the meter housing from the line.

METER INSTALLATION

The meter is designed for installations where flow is in one direction only. A separate strainer is required to ensure optimum flow conditioning and protection of the measuring element. Companion flanges for installation of meters on various pipe types and sizes are available in cast iron or NL bronze as an option.

REGISTERS / ENCODERS

Standard—Sweep-Hand Registration

The standard register is a straight-reading, permanently sealed magnetic drive register. Dirt, moisture, tampering and lens fogging problems are eliminated. The register has a six-odometer wheel totalization display, 360° test circle with center sweep hand, and flow finder to detect leaks. Register gearing is made of self-lubricating engineered polymer, which minimizes friction and provides long life. The multi-position register simplifies meter installation and reading. The register capacity is 100,000,000 gallons (10,000,000 ft³, 1,000,000 m³).

Optional—Encoders for AMR/AMI Reading Solutions

AMR/AMI solutions are available for all Recordall Compound Series meters. All reading options can be removed from the meter without disrupting water service. Badger Meter encoders provide years of reliable, accurate readings for a variety of applications and are also available pre-wired to Badger Meter approved AMR/AMI solutions. See details at www.badgermeter.com.

SPECIFICATIONS

Compound Series Model	2 in. (50 mm)	3 in. (80 mm)	4 in. (100 mm)	6 in. (150 mm)
Meter Flanges, Class 150	2 in. elliptical or round	3 in. round	4 in. round	6 in. round
	(50 mm)	(80 mm)	(100 mm)	(150 mm)
Typical Operating Range (100% ± 1.5%)	0.5...200 gpm (0.1...45 m ³ /h)	0.5...450 gpm (0.1...102 m ³ /h)	0.75...1000 gpm (0.17...227 m ³ /h)	0.75...2000 gpm (0.17...454.4 m ³ /h)
Low Flow Registration (95% minimum)	0.25 gpm (0.06 m ³ /h)	0.25 gpm (0.06 m ³ /h)	0.375 gpm (0.09 m ³ /h)	0.375 gpm (0.09 m ³ /h)
Maximum Continuous Flow	170 gpm (38.3 m ³ /h)	400 gpm (90.3 m ³ /h)	800 gpm (181.6 m ³ /h)	1500 gpm (340.5 m ³ /h)
Pressure Loss at Maximum Continuous Flow	5.4 psi at 170 gpm	6.0 psi at 400 gpm	11.0 psi at 800 gpm	9.3 psi at 1500 gpm
	(0.38 bar at 38.3 m ³ /h)	(0.41 bar at 90.3 m ³ /h)	(0.75 bar at 181.6 m ³ /h)	(0.64 bar at 340.5 m ³ /h)
Crossover Flow Rate, Typical	12 gpm (2.73 m ³ /h)	12 gpm (2.73 m ³ /h)	20 gpm (4.54 m ³ /h)	30 gpm (6.81 m ³ /h)
Pressure Loss at Crossover	3.5 psi (0.24 bar)	4.0 psi (0.28 bar)	4.0 psi (0.28 bar)	5.0 psi (0.35 bar)
Minimum Crossover Accuracy	97%	97%	97%	95%
Maximum Operating Pressure	150 psi (10 bar)			
Maximum Operating Temperature	105° F (41° C)			
NPT Test Port	1-1/2 in.		2 in.	

Materials

Meter Housing & Cover	Lead-free bronze alloy
Turbo Cast Head	Lead-free bronze alloy
Nose Cone & Straightening Vanes	Thermoplastic
Rotor	Thermoplastic
Rotor Radial Bearings	Lubricated thermoplastic
Rotor Thrust Bearing	Sapphire jewels
Rotor Bearing Pivots	Passivated 316 stainless steel
Calibration Mechanism	Stainless steel & thermoplastic
Measuring Chamber & Disc	Thermoplastic
High Flow Valve	Stainless steel & thermoplastic
Magnets	Ceramic
Register Lens	Glass
Register Housing & Cover	Thermoplastic or bronze
Trim	Stainless steel
Drain Plug (3/4 in.)	Stainless steel or lead-free bronze alloy
Test Plug	Stainless steel or lead-free bronze alloy

PHYSICAL DIMENSIONS

Compound Series Model	2 in. Elliptical (50 mm)	2 in. Round (50 mm)	3 in. (80 mm)	4 in. (100 mm)	6 in. (150 mm)
Meter & Pipe Size	2 in. (50 mm)		3 in. (80 mm)	4 in. (100 mm)	6 in. (150 mm)
Net Weight	45 lb (20 kg)		51 lb (23 kg)	85 lb (38 kg)	152 lb (69 kg)
Shipping Weight	63 lb (29 kg)		79 lb (36 kg)	120 lb (54 kg)	200 lb (90 kg)
Length (A)	15-1/4 in. * (387 mm)		17 in. (432 mm)	20 in. (508 mm)**	24 in. (610 mm)
Width (B)	7-3/8 in. (187 mm)		8-1/2 in. (216 mm)	9-1/8 in. (232 mm)	12-3/8 in. (314 mm)
Height (C)	5-7/8 in. (149 mm)		6-5/8 in. (168 mm)	7-1/4 in. (184 mm)	8-7/8 in. (225 mm)
Flange (D)	5/8 in. (16 mm)		3/4 in. (19 mm)	7/8 in. (22 mm)	15/16 in. (24 mm)
Bolt Circle (E)	4-1/2 in. (114 mm)	4-3/4 in. (121 mm)	6 in. (152 mm)	7-1/2 in. (191 mm)	9-1/2 in. (241 mm)
Centerline (C) to Base (F)	2-3/4 in. (70 mm)		3-5/8 in. (92 mm)	4-1/4 in. (108 mm)	5-3/8 in. (137 mm)
Number of Bolts	2	4	4	8	8

* Adapter available to increase total length to 17 in. (432 mm).

**Adapter available to increase total length to 24 in. (610 mm).

Elliptical Flange (2 in. Only)

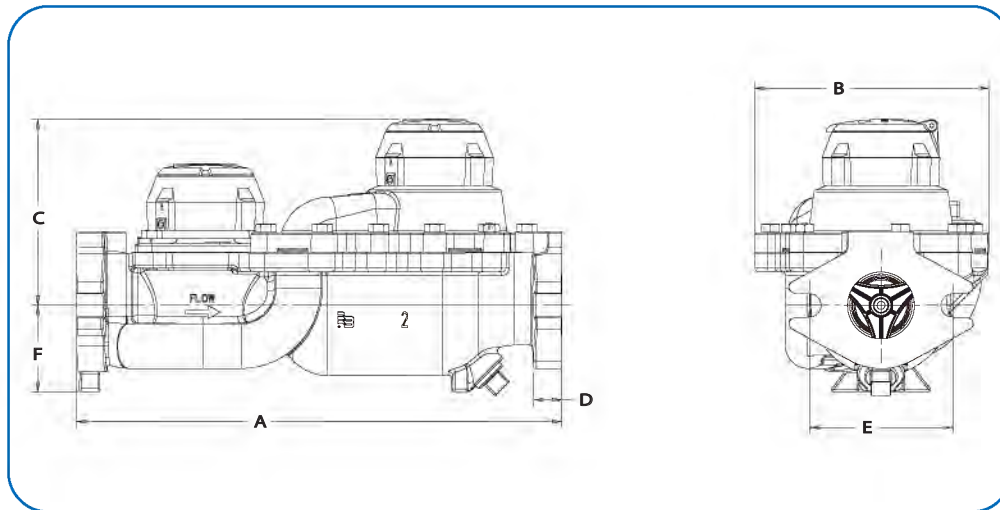

Round Flange

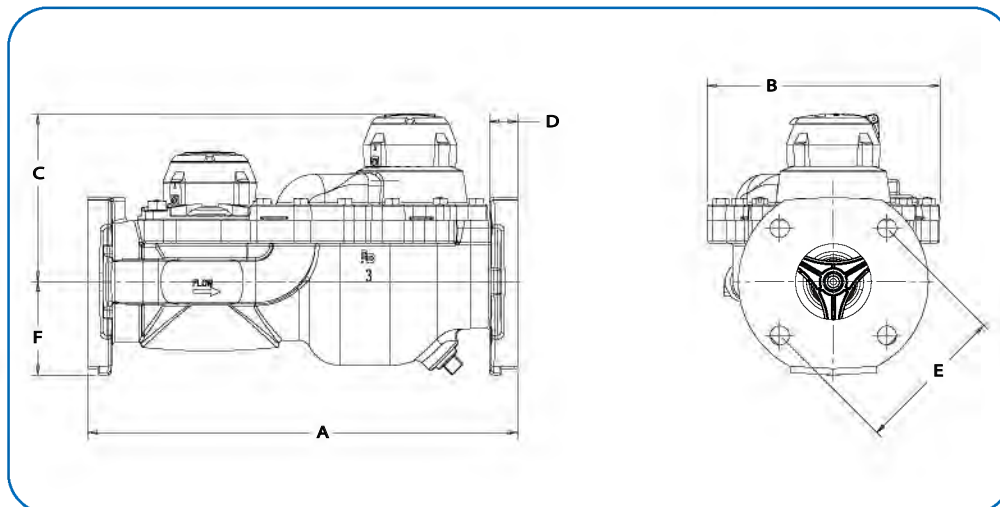

ACCURACY CHARTS

Rate of flow in gallons per minute (gpm). Dashed line on each chart (— — —) represents crossover flow accuracy.

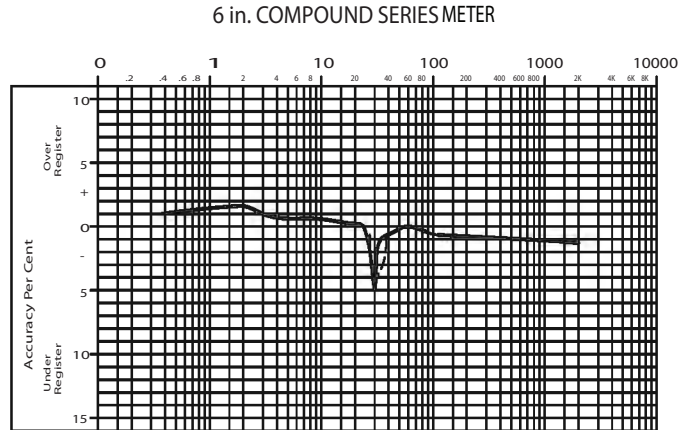
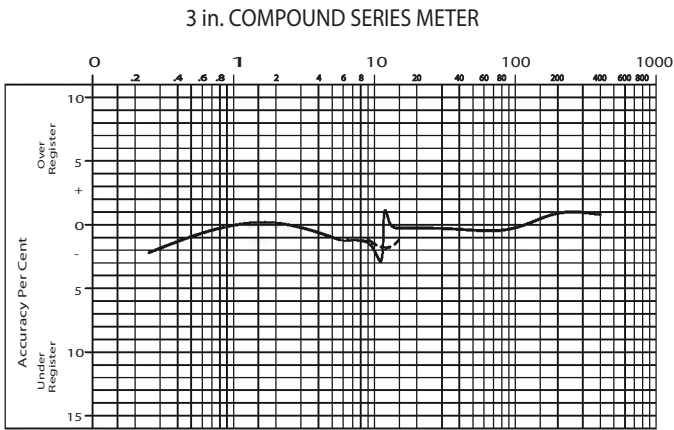
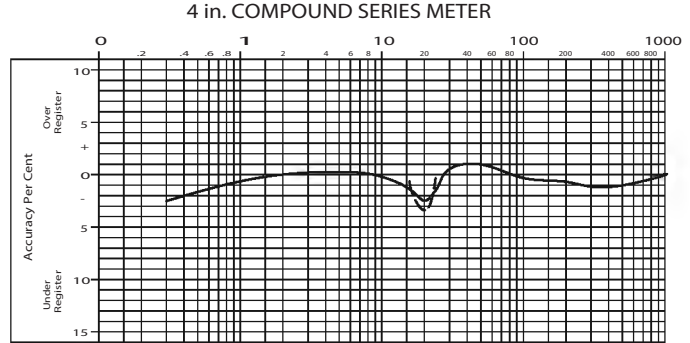
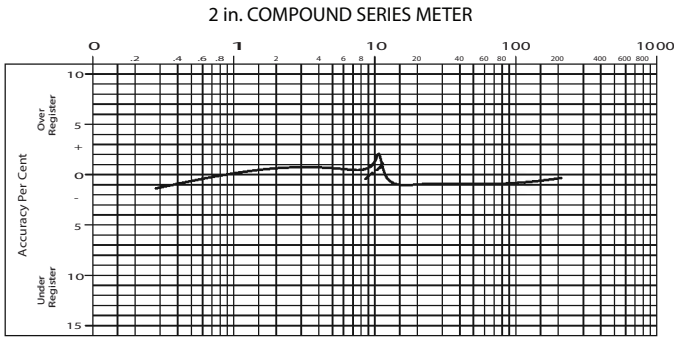

PRESSURE LOSS CHART

Rate of flow in gallons per minute (gpm)

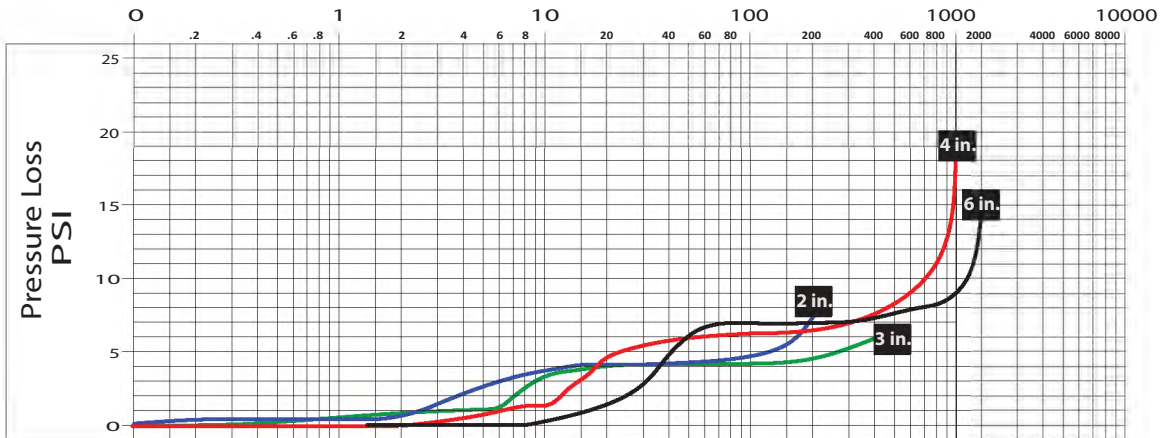

SMART WATER IS BADGER METER

GALAXY, ORION and Recordall are registered trademarks of Badger Meter, Inc. Other trademarks appearing in this document are the property of their respective entities. Due to continuous research, product improvements and enhancements, Badger Meter reserves the right to change product or system specifications without notice, except to the extent an outstanding contractual obligation exists. © 2020 Badger Meter, Inc. All rights reserved.



Badger Meter

Recordall® Combo Meter

Lead-Free Bronze Alloy, Size 8"
NSF/ANSI Standards 61 and 372 Certified

DESCRIPTION

The Badger Meter Recordall Combo meters meet or exceed the most recent revision of AWWA Standard C700 and are available in a lead-free bronze alloy. The Combo meters comply with the lead-free provisions of the Safe Drinking Water Act, are certified to NSF/ANSI Standards 61 and 372 (Trade Designation: Combo-01) and carry the NSF-61 mark on the housing. All components of the lead-free bronze alloy meter (housing, measuring element, seals, and so on) comprise the certified system.

The Combo meter combines two metering technologies in one innovative package. A positive displacement chamber measures low flow, while a turbine chamber records high flow.

The 8-inch Combo meter features:

- Spring-loaded check valve to facilitate one-way water flow through appropriate measurement chambers, in line with demand.
- Permanently sealed, tamper-resistant register or encoder.
- Meters and encoders that are compatible with Badger Meter AMR/AMI systems and other approved reading technologies

Badger Meter ORION® and GALAXY® AMR/AMI meter reading systems are available for all Combo meters. Itron® ERT reading systems are also available. An optional summator can be provided as an integral part of the register assembly. All register options are removable from the meter without disrupting water service.

TAMPER-PROOF FEATURES

Unauthorized removal of the register or encoder is inhibited by the use of an optional tamper detection seal wire screw, TORX® tamper-resistant seal screw or the proprietary tamper-resistant keyed seal screw. Each can be installed at the meter site or at the factory.

APPLICATIONS

Use the Recordall Combo meter for measuring potable cold water in commercial and industrial applications where flow is in one direction only. The meter is an ideal choice for facilities that experience rapid and wide fluctuations in water demand, such as hospitals, universities, residential complexes and manufacturing or processing facilities.

OPERATION

As water enters the meter at low flow rates, a spring-loaded check valve on the downstream side holds the clapper assembly in a closed position. Water is diverted through a bypass to the disc measuring chamber. As the flow rate increases, a pressure differential is created that opens the check valve and allows water to flow through the turbine chamber. A small amount of water will continue to flow through the bypass when the clapper assembly is fully open.



Rotor and disc movements are transmitted by magnetic drive couplings to individual register odometers. The direct magnetic drive provides a positive, reliable and dependable register coupling for straight-reading or remote reading options. The self-lubricating thermoplastic register gearing is designed to minimize friction and provide long life.

OPERATING PERFORMANCE

The Recordall Combo meter meets or exceeds registration accuracy for low, normal operating, maximum continuous operation, and changeover flow rates as specified in AWWA Standard C702.

CONSTRUCTION

The Recordall Combo meter's construction complies with ANSI and AWWA C702 standards. It consists of a stainless steel spool with bypass port, turbine measuring chamber, a check valve with bypass piping, a disc measuring chamber, valve assembly, and sealed direct reading registers. To simplify maintenance, the registers and measuring elements can be removed without removing the meter housing from the line.

METER INSTALLATION

The meter is designed for installations where flow is in one direction only. A separate strainer is required to ensure optimum flow conditioning and protection of the measuring element. Companion flanges for installation of meters on various pipe types and sizes are available in cast iron or NL bronze as an option.

REGISTERS / ENCODERS

Standard—Sweep-Hand Registration

The standard register is a straight-reading, permanently sealed magnetic drive register. Dirt, moisture, tampering and lens fogging problems are eliminated. The register has a six-odometer wheel totalization display, 360° test circle with center sweep hand, and flow finder to detect leaks. Register gearing is made of self-lubricating engineered polymer, which minimizes friction and provides long life. The multi-position register simplifies meter installation and reading. The register capacity is 100,000,000 gallons (10,000,000 ft³, 1,000,000 m³).

Optional—Encoders for AMR/AMI Reading Solutions

AMR/AMI solutions are available for all Recordall Combo meters. All reading options can be removed from the meter without disrupting water service. Badger Meter encoders provide years of reliable, accurate readings for a variety of applications and are also available pre-wired to Badger Meter approved AMR/AMI solutions. See details at www.badgermeter.com.

SPECIFICATIONS

Combo Meter Model	8" Model (200 mm)
Meter Flange, AWWA Class D (C-207)	8" (200 mm)
Typical Operating Range (100% ± 1.5%)	2.5...4500 gpm (0.56...1022 m ³ /h)
Low Flow Registration (95% minimum)	1.25 gpm (0.28 m ³ /h)
Maximum Continuous Flow	3500 gpm (795 m ³ /h)
Pressure Loss at Maximum Continuous Flow	6.3 psi at 3500 gpm (0.43 bar at 795 m ³ /h)
Pressure Loss at Crossover	2 psi (0.138 bar)
Minimum Crossover Accuracy	90%
Maximum Operating Pressure	150 psi (10 bar)
Maximum Operating Temperature	105° F (40° C)
Check Valve	Conforms to UL 312 and FM 1045
Bypass Line	Specify right-facing (standard, as shown) or left-facing assembly

Materials

Meter Housing	Fusion-bonded epoxy coated ductile cast iron
Bypass Meter Housing	Lead-free bronze alloy
Bypass Measuring Chamber	Injection-molded thermoplastic
Bypass	Brass piping conforming to AWWA C800, NSF 61 & 372 compliant
Spool Body	Stainless steel, with stainless steel bypass port. Standard steel flange connections with zinc chromate plating.
Nose Cone & Straightening Vanes	Thermoplastic
Rotor	Thermoplastic
Rotor Radial Bearings	Lubricated thermoplastic
Rotor Thrust Bearing	Sapphire jewels
Rotor Bearing Pivots	Passivated 316 stainless steel
Calibration Mechanism	Stainless steel & thermoplastic
Magnet	Ceramic
Clapper Assembly (clapper, spring, hinge & pins)	Stainless steel
Clapper Seal	Elastomeric, EPDM
Valve Seat	Stainless steel
Valve Body & Cover Plate	Fusion-bonded epoxy coated steel
Valve Cover Plate Gasket	Elastomeric sheet
Register Housing & Cover	Thermoplastic or bronze
Trim	Zinc-plated stainless steel or (optional) all stainless steel.
Test Plug, 2"	Stainless steel or lead-free bronze

PHYSICAL DIMENSIONS

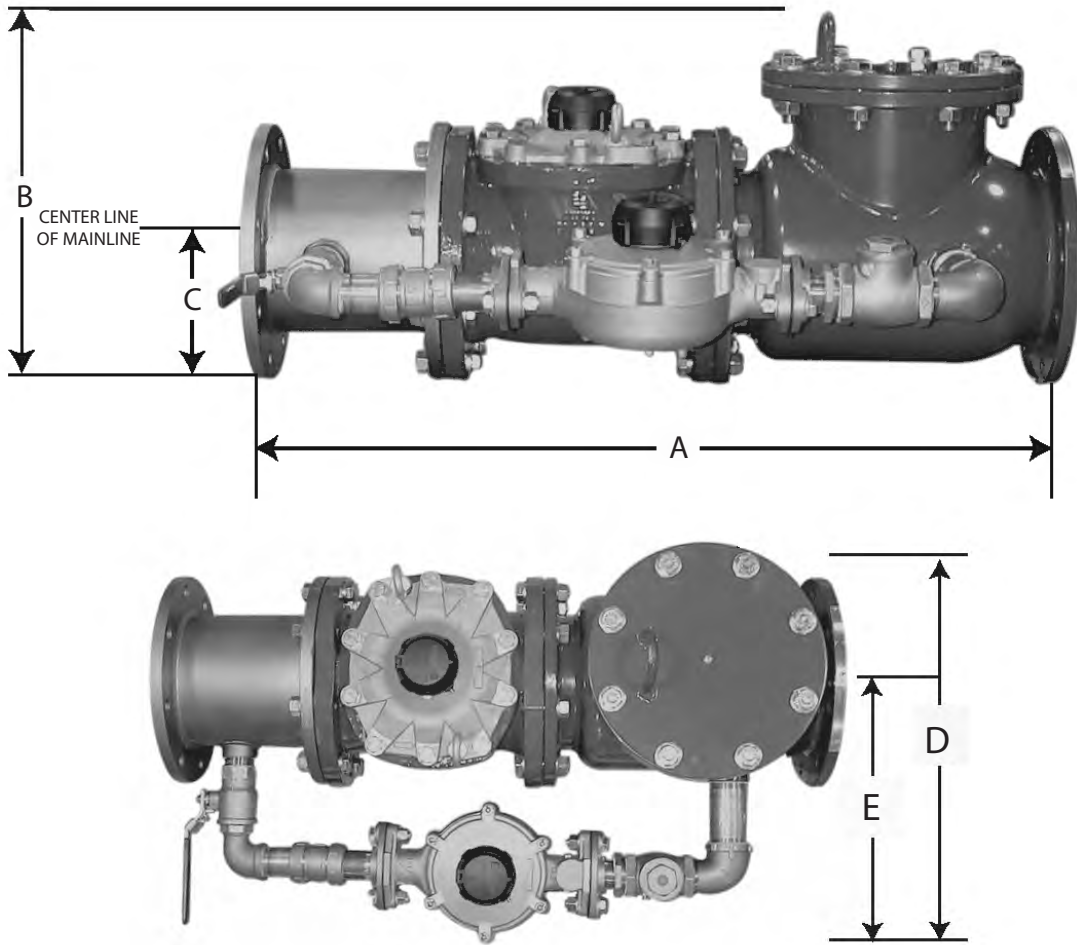

Combo Meter Model	8" Model (200 mm)
Meter & Pipe Size	8" (200 mm)
Shipping Weight (fully assembled)	357 lb (162 kg)
Length (A)	41-7/8" (1063 mm)
Height (B)	19-1/2" (495 mm)
Height (C)	6-3/4" (171 mm)
Width (D)	23-3/4" (603 mm)
Width (E)	17" (732 mm)

PRESSURE LOSS CHART

Rate of flow in gallons per minute (gpm)

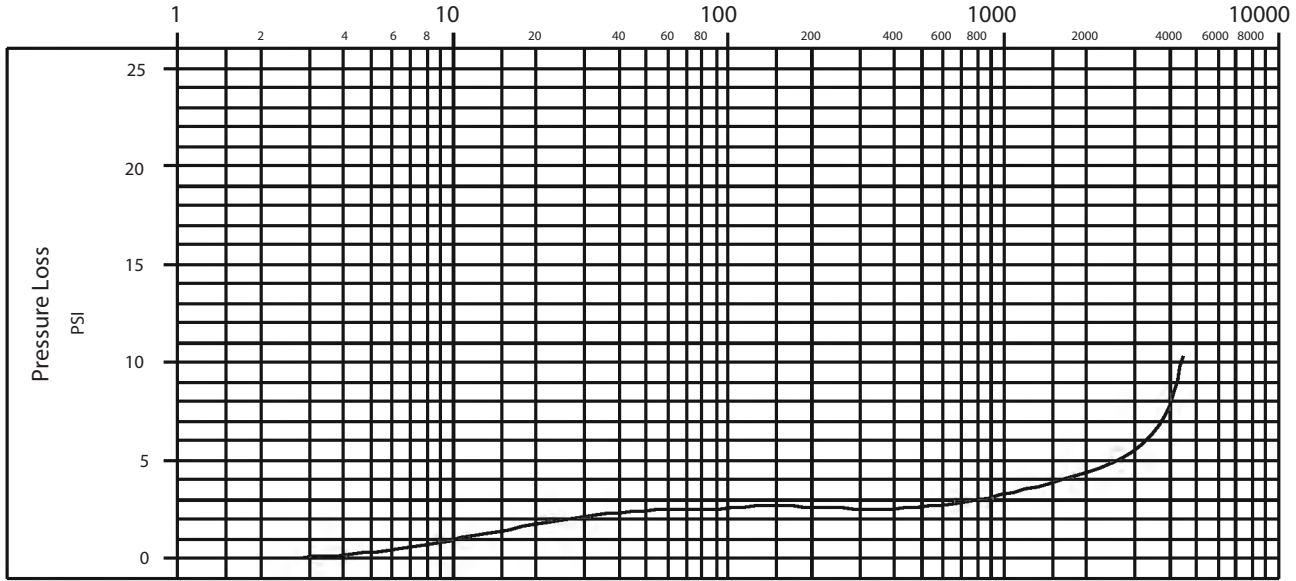

ACCURACY CHART

Rate of flow in gallons per minute (gpm)

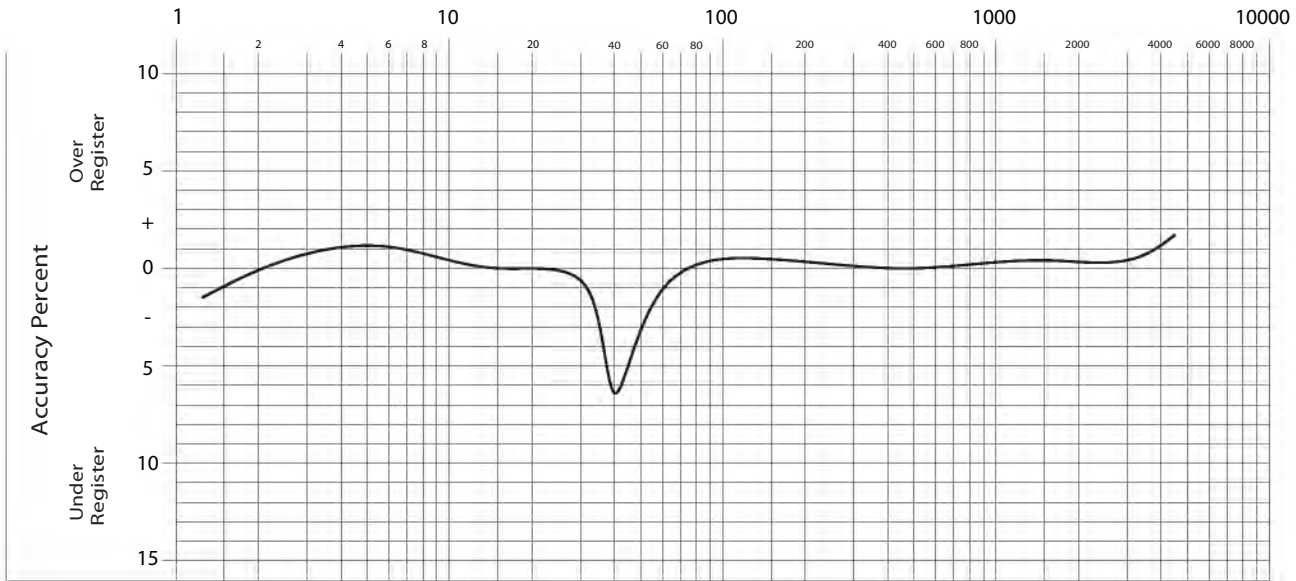

GALAXY, ORION, and Recordall are registered trademarks of Badger Meter, Inc. Other trademarks appearing in this document are the property of their respective entities. Due to continuous research, product improvements and enhancements, Badger Meter reserves the right to change product or system specifications without notice, except to the extent an outstanding contractual obligation exists. © 2013 Badger Meter, Inc. All rights reserved.

www.badgermeter.com

The Americas | Badger Meter | 4545 West Brown Deer Rd | PO Box 245036 | Milwaukee, WI 53224-9536 | 800-876-3837 | 414-355-0400
 México | Badger Meter de las Americas, S.A. de C.V. | Pedro Luis Ogazón N°32 | Esq. Angelina N°24 | Colonia Guadalupe Inn | CP 01050 | México, DF | México | +52-55-5662-0882
 Europe, Middle East and Africa | Badger Meter Europa GmbH | Nürtinger Str 76 | 72639 Neuffen | Germany | +49-7025-9208-0
 Czech Republic | Badger Meter Czech Republic s.r.o. | Maříkova 2082/26 | 621 00 Brno, Czech Republic | +420-5-41420411
 Slovakia | Badger Meter Slovakia s.r.o. | Racianska 109/B | 831 02 Bratislava, Slovakia | +421-2-44 63 83 01
 Asia Pacific | Badger Meter | 80 Marine Parade Rd | 21-04 Parkway Parade | Singapore 449269 | +65-63464836
 China | Badger Meter | 7-1202 | 99 Hangzhong Road | Minhang District | Shanghai | China 201101 | +86-21-5763 5412

ATTACHMENT C.4

HOW TO READ YOUR METER

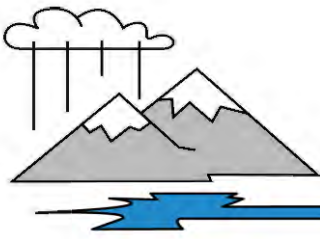

BELLA VISTA WATER DISTRICT

11368 E. STILLWATER WAY • REDDING, CALIFORNIA 96003-9510
TELEPHONE (530) 241-1085 • FAX (530) 241-8354

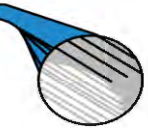

Bella Vista Water District reads your water meter every other month to determine your water use and bill. You can also use your meter to monitor your own usage and to check for water leaks.

Locate your Water Meter

Meters are inside a concrete box with the word “water” marked on the lid. Meters are usually located at the front of the property near the street. In some cases, our customers in outlying areas can have the meter located in the rear of their property.

How to Read the Water Meter

Remove the concrete lid of the water meter box. Inside you will find a meter similar to the one shown in Figure 1. Once inside the meter box, lift the lid covering the face of the meter register. If register lens is dirty, a light wipe with a damp cloth will clear lens for an accurate reading. Always remember to close the register cover after reading meter to avoid exposure to cracking or scratching of lens.



Figure 1

The meter below is an example of what most of our water meters look like. The numeric dials rotate when water passes through the meter. One full rotation of the sweep hand equals one cubic foot of water. The odometer records total water usage similar to how a car records mileage. The water meter odometer records water use in cubic feet. The digits right to left represent 1 cubic foot, 10 cubic feet, 100 cubic feet, and so on. When the meter is read for billing, all the numbers from left to right are recorded, however are billed in hundreds of cubic feet (HCF) only.

<p>Low Flow Indicator, aka Leak Indicator</p> <p>This small dial will rotate if water is passing through the meter. It is an indication of very low flows that would be visually undetectable on the regular sweep hand. If no one is using water, but the dial is turning, you may have an undiscovered leak in your plumbing system.</p>		<p>Sweep Hand</p> <p>On this meter, one rotation of the sweep hand is equal to one cubic foot or 7.48 gallons</p> <hr/> <p>Cubic Foot Odometer</p> <p>Usually, the last numbers (in black) on the odometer are non-rotating or printed. For every 100 rotations of the sweep hand, the white digits on the odometer will increase by one to reflect 100 cubic feet of water use (748 gallons)</p>
	<p>Cubic Foot Odometer</p> <p>1 cubic foot 10 cubic feet 100 cubic feet</p>	

How to Monitor Your Water Use

Use these steps to measure your water usage over a period of time.

1. Read the odometer and write down all the numbers from left to right and list the date it was read. After a period of time, read the odometer again and list the reading and date.
2. Subtract the first reading from the second reading. This is your water usage in cubic feet.
3. To convert your usage into gallons, multiply the usage by 7.48.
4. To get a daily average of usage in gallons, divide the total usage by the number of days between readings.

How to Check for Leaks

If your water usage seems higher than normal, you can monitor your meter for leaks. A leak as small as a pencil lead, at a pressure rate of 40 psi, can result in usage of 8,000 gallons (1,070 cf) per day. To check for leaks, turn all water off indoors and outdoors. This includes any devices such as ice makers, washing machines, sprinklers, etc. Once water is off, and the low flow indicator is moving, this may indicate there is a leak. If the meter shows no obvious movement, note the reading and return in a few hours to see if there has been any change. If any water is used during that time, the meter reading will change. If you find that there is movement on the meter when there should not be, this may be an indication of a leak. Check all appliances (dishwasher, clothes washer, ice machine), faucets, toilets, pool system, irrigation system and any other water systems for possible leaks. If possible, close section valves to isolate portions of the system and determine the section with the leak.

If you need assistance locating your meter, contact the District office at (530) 241-1085 during normal business hours.

Calculate Water Usage (Sample)

1. Meter Readings:



Reading #1

Date: 7/1/10

Odometer Reading: 1357.25
cubic feet



Reading #2

Date: 7/5/10

Odometer Reading: 1636.38
cubic feet

Days Between

Readings: 4

2. Water Use (Cubic Feet):

Reading #2: 1636.38 (cubic feet)

Reading #1: - 1357.25 (cubic feet)

= 279.13 (cubic feet used)

3. Water Use (gallons):

Cubic Feet Used: 279.13 x 7.48 gallons = 2087.90 gallons used

4. Average Daily Water Use:

Gallons Used: 2087.90

÷ 4 (# of days between readings)

= 521.98 (average gallons per day)

÷ 24 (hours per day)

= 21.75 (gallons per hour)

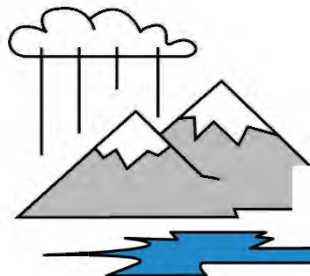

BELLA VISTA WATER DISTRICT

11368 E. STILLWATER WAY • REDDING, CALIFORNIA 96003-9510
TELEPHONE (530) 241-1085 • FAX (530) 241-8354

E-SERIES REGISTERS

Bella Vista Water District reads your water meter every other month to determine your water use and bill. You can also use your meter to monitor your own usage and to check for water leaks.

Locate your Water Meter

Meters are inside a concrete box with the word “water” marked on the lid. Meters are usually located at the front of the property near the street. In some cases, our customers in outlying areas can have the meter located in the rear of their property.

How to Read the Water Meter

Remove the concrete lid of the water meter box. Inside you will find a meter similar to the one shown in diagram below. Once inside the meter box, lift the lid covering the face of the meter register. If register lens is dirty, a light wipe with a damp cloth will clear lens for an accurate reading. Always remember to close the register cover after reading meter to avoid exposure to cracking or scratching of lens.

On the next page is an example of what our E Series meters look like. The digital numbers change when water passes through the meter. One full rotation of the sweep hand equals one cubic meter odometer records water use in cubic feet. The digits right to left represent 1 cubic foot, 10 cubic feet, 100 cubic feet, and so on. When the meter is read for billing, all the numbers from left to right are recorded, however are billed in hundreds of cubic feet (HCF) only.

How to Monitor Your Water Use over a period of time

1. Read the odometer and write down the first 4 or 5 numbers (depending on your meter size, see note above) from left to right and list the date it was read. After a period of time, read the odometer again and list the reading and date.
2. Subtract the first reading from the second reading. This is your water usage in cubic feet.
3. To convert your usage into gallons, multiply the usage by 7.48.
4. To get a daily average of usage in gallons, divide the total usage by the number of days between readings.

When reading the E-Series meter you read the numbers with the black lines above and below them.

For a 1" meter or smaller you use the first 4 numbers from left to right. For 1.5" meter or larger you use the first 5 numbers from left to right. There is no decimal placement on the register.



How to Check for Leaks

If your water usage seems higher than normal, you can monitor your meter for leaks. A leak as small as a pencil lead, at a pressure rate of 40 psi, can result in usage of 8,000 gallons (1,070 cf) per day. To check for leaks, turn all water off indoors and outdoors. This includes any devices such as ice makers, washing machines, sprinklers, etc. Once water is off, and the low flow indicator is moving, this may indicate there is a leak. If the meter shows no obvious movement, note the reading and return in a few hours to see if there has been any change. If any water is used during that time, the meter reading will change. If you find that there is movement on the meter when there should not be, this may be an indication of a leak. Check all appliances (dishwasher, clothes washer, ice machine), faucets, toilets, pool system, irrigation system and any other water systems for possible leaks. If possible, close section valves to isolate portions of the system and determine the section with the leak.

If you need assistance locating your meter, contact the District office at (530) 241-1085 during normal business hours.

ATTACHMENT C.4

Standard Operating Procedure for Replacement Meter Testing

STANDARD OPERATING GUIDELINE

Replacement Meter Testing

Scope and Application:

Testing replaced meters for accuracy.

Frequency:

To be done at the conclusion of each meter route replacement.

Interference:

Meter testers not properly calibrated, not having proper fittings, adapters, etc.

Apparatus and Materials:

Nuts, bolts, meter gaskets, hoses, adapters, meter testers, flow benches. Worksheet for recording the results.

Reagents:

N/A

Calibration:

Make sure testing devices have been properly calibrated.

Procedures:

Select a 10% representative sample of the meters removed and at least one of each meter type (i.e. disk, multi-jet, turbo, etc.) for testing. For meters up to 1" use the Mars MUN-1 meter tester. For meters 1½" and larger use the Badger 2½" tester. Set the test area up at the Water Treatment Plant Recycle Pond so the water used for testing will flow into the pond to be recycled. Determine the proper type of fittings, adapters etc. for the meter to be tested. Connect the meter to the proper tester. Determine the type of meter being tested and conduct the flow test using AWWA manual for meter testing M6, table 5-3 for proper flow rates. Record testing results and turn records into the Engineering Department.

Safety:

Be aware of surroundings; make sure all fittings and hoses are secure.

Quality Control:

Accurate flow tests. Using proper tables for type of meter.

References:

AWWA Manual of Practice, M6 Water Meters – Selection, Installation, Testing, and Maintenance, 5th ed.

Approved By:

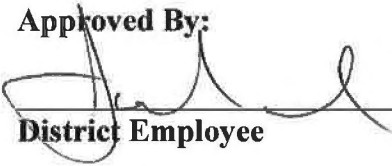

District Employee

4-11-19
Date:



Distribution Superintendent

4-11-19
Date:

ATTACHMENT D

RATES AND SAMPLE BILLS

- D.1 BVWD Schedule of Bimonthly Water Rates**
- D.2 Sample Bill: Residential/Commercial/Rural/Institutional Customers**
- D.3 Sample Bill: Agricultural Customer**
- D.4 Customer Account Information Available Online**

ATTACHMENT D.1

**Bella Vista Water District
Schedule of Bimonthly Water Rates**

BELLA VISTA WATER DISTRICT

11368 E. STILLWATER WAY
REDDING, CA 96003
(530) 241-1085 ♦ (530) 241-8354
www.bvwd.org

SCHEDULE OF BIMONTHLY WATER RATES

AGRICULTURAL

<u>Meter Class</u>	<u>Base Rates</u>
50	\$69.14
100	\$77.57
160	\$84.98
200	\$89.08
300	\$97.67
450	\$107.99
900	\$130.63
1200	\$142.31
1500	\$152.47
2000	\$167.17
2500	\$179.95
3300	\$197.75
4500	\$220.47
6000	\$244.55

The commodity rate is \$76.18 per acre-foot (\$0.1748 per HCF)

Water Treatment Plant Improvement Loan Repayment

\$14.00 bimonthly charge for all customers.

NDU Credit

Agricultural accounts that have no domestic use will receive a \$4.00 bimonthly base charge reduction referred to as a NDU credit.

BELLA VISTA WATER DISTRICT

11368 E. STILLWATER WAY
REDDING, CA 96003
(530) 241-1085 ♦ (530) 241-8354
www.bvwd.org

SCHEDULE OF BIMONTHLY WATER RATES

RESIDENTIAL, RURAL, COMMERCIAL, PUBLIC INSTITUTIONAL AND LANDSCAPE IRRIGATION

<u>Meter Class</u>	<u>Base Rates</u>
20	\$42.53
30	\$45.58
50	\$50.30
100	\$58.72
160	\$66.13
200	\$70.24
300	\$78.84
450	\$89.15
900	\$111.79
1200	\$123.47
1500	\$133.63
2000	\$148.31
2500	\$161.11
3300	\$178.92
4500	\$201.62
6000	\$225.72

The commodity rate is \$0.59 per HCF (One hundred cubic foot).

Water Treatment Plant Improvement Loan Repayment

\$14.00 bimonthly charge for all customers.

Fire Service Rates

<u>Line Size</u>	<u>Base Rate</u>
2	\$27.22
3	\$37.03
4	\$52.26
6	\$71.86
8	\$90.38
10	\$113.25

WATER EQUIVALENTS TABLE

1 Cubic Foot = 7.48 gallons = 62.4 pounds of water
1 Acre Foot = 43,560 cubic feet = 325,900 gallons

An acre foot covers (1) acre of land (1) foot deep

1 cubic foot per second (cfs) = 450 gallons per minute or 646,320 gallons per day

For 24 hours = 1.983 acre feet

For 30 days = 59.5 acre feet

For one year = 724 acre feet

PROCEDURE FOR METER READING

If register lens is dirty, a light wipe with a damp cloth will clear lens for an accurate reading. Always remember to close the register cover after reading meter to avoid exposure to cracking or scratching of lens.

One of the most important factors in a correct reading is to note the proper number of digits. Read the meter register from left to right.

EXAMPLE OF A CUBIC FOOT METER:

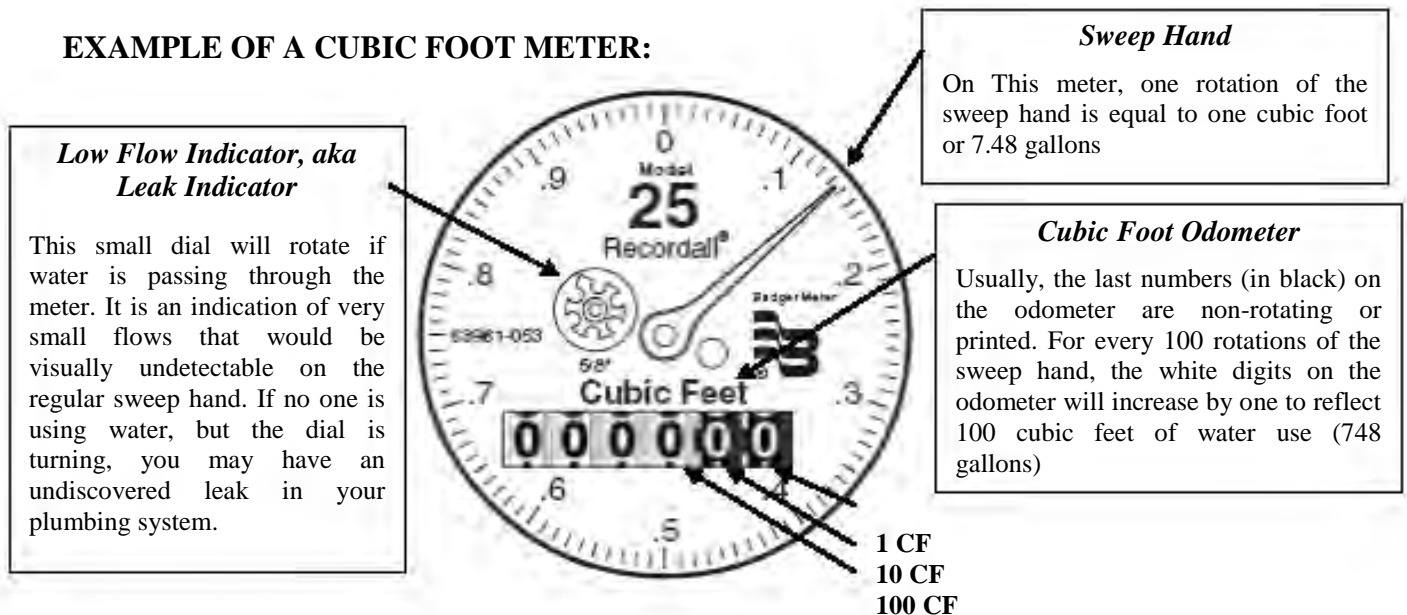

BILLING: You will be billed for water service bimonthly; thus, the water meter will be read as nearly as possible on the same day every two (2) months. The bills are due and payable on the date of receipt and become delinquent twenty-two (22) days thereafter. Payments can be made to the District office by mail, in person, or online at: www.invoicecloud.com/bywd. The District is currently using Invoice Cloud which allows for automatic payment deductions and only charges a small service fee of \$0.95 if utilizing (e-checks) your checking account or \$2.95 if you would like to continue to utilize your credit or debit cards. All fees are charged by Invoice Cloud and you will no longer see an adjustment on your Bella Vista Utility Billing for any charges.

OFFICE HOURS: The district office is open from 8:00 a.m. to 5:00 p.m., Monday through Thursday, and 8:00 a.m. to 4:00 p.m. on Fridays, except holidays. For after-hour emergencies, there is an answering service.

ATTACHMENT D.2

Sample Bill: Residential/Commercial/Rural/Institutional Customers



SAMPLE M&I BILL

BELLA VISTA WATER DISTRICT

11368 E. STILLWATER WAY • REDDING, CA 96003-9510
(530) 241-1085 • FAX (530) 241-8354
<http://www.bvwd.org>

PLEASE RETURN THIS STUB WITH PAYMENT

DUE DATE	AMOUNT DUE BY DUE DATE
7/23/2020	171.68
ACCOUNT NUMBER	
[REDACTED]	

[REDACTED]
PALO CEDRO, CA 96073

Parcel # 061-[REDACTED]-000

Please fold along perforation, detach and return the top portion with your payment.

Previous Balance For ALL Locations	:	93.04	Payments:	93.04
Beginning Balance as of 7/2/2020	:	0.00		
[REDACTED]		Balance Forward	Current Charges	
Parcel # 061-[REDACTED]-000				
Usage History (in Hundreds of Cubic Feet)				
Usage This Period Last Year	:			
Usage This Period This Year	:	182		
Usage Prior 12 Months	:			
BVWD 05/01/2020 - 07/01/2020 (meter 0041959848)				
		Previous	Current	
Readings		1714	1896	
		BASE RATE	0.00	50.30
		USAGE	0.00	107.38
		TREATMENT DEBT SERV.	0.00	14.00
		Total for Service		171.68
Total for [REDACTED]				171.68

Account Number	:	[REDACTED]	Invoice Date :	7/2/2020
Name	:	[REDACTED]		
Due Date	:	7/23/2020	TOTAL AMOUNT DUE	171.68



ATTACHMENT D.3

Sample Bill: Agricultural Customer



SAMPLE AG BILL

BELLA VISTA WATER DISTRICT

11368 E. STILLWATER WAY • REDDING, CA 96003-9510
(530) 241-1085 • FAX (530) 241-8354
<http://www.bvwd.org>

PLEASE RETURN THIS STUB WITH PAYMENT

DUE DATE	AMOUNT DUE BY DUE DATE
9/23/2021	193.01
ACCOUNT NUMBER	
[REDACTED]	

[REDACTED]
PALO CEDRO, CA 96073

Parcel # [REDACTED]

Please fold along perforation, detach and return the top portion with your payment.

Previous Balance For ALL Locations	:	253.56	Payments:	253.56
Beginning Balance as of 9/2/2021	:	0.00		
[REDACTED]		Balance Forward		Current Charges
Parcel # [REDACTED]				
Usage History (in Hundreds of Cubic Feet)				
Usage This Period Last Year	:			
Usage This Period This Year	:	200		
Usage Prior 12 Months	:			
BVWD		07/01/2021 - 09/01/2021 (meter 004195 [REDACTED])		
		Previous	Current	
Readings		2895	3095	
		BASE RATE	0.00	51.01
		TREATMENT DEBT SERV.	0.00	14.00
		ALLOTMENT	0.00	128.00
		Total for Service		193.01
Total for [REDACTED]				193.01

Account Number	:	[REDACTED]	Invoice Date :	9/2/2021
Name	:	[REDACTED]		
Due Date	:	9/23/2021	TOTAL AMOUNT DUE	193.01



ATTACHMENT D.4

BILL PAYMENT SCREENS

Bill Payment

Bella Vista Water District offers a wide variety of convenient payment options for our customers. Simply choose the option that best suits your needs.

Online: The District has recently changed from I-Web to Invoice Cloud which allows for automatic payment deductions and only charges a small service fee of .95 if utilizing (e-checks) your checking account and \$2.95 if you would like to continue to utilize your credit or debit cards. The payment website can be accessed at www.invoicecloud.com/bvwd. All fees are charged by Invoice Cloud and you will no longer see an adjustment on your Bella Vista Utility Billing for any charges.

Credit Card: You can pay your bill by Visa or Master Card two ways: a. In person at the District office. b. By phone by calling the District Customer Service department at 530-241-1085. This is a fee based service and you will be charged the applicable fees by Invoice Cloud.

Mail: We accept checks and money orders by mail at the address listed below. Your billing statement will include a return envelope to mail a check with each cycle. Please be sure to include the top portion of your bill stub and please do not send cash.

In Person: You may pay by cash, check, money order, Visa or Mastercard at the District office, located at 11368 E. Stillwater Way in Redding.

(1) Note: Electronic Payment transactions are not free. Credit card and financial transaction providers charge the District for credit card transactions. Since the District is a public non-profit entity, these charges must be passed onto our customers.

Delinquent Accounts Shut Off Policy SB 998 is located under the Resources Tab Policies along with information on how to obtain the policy in multiple languages.

Payment Address

Bella Vista Water District
11368 East Stillwater Way
Redding, CA 96003

[Pay Your Bill Now](#)

[Click to Pay Your Bill Now](#)

Pay or View Bills

Pay online with One Time Pay, no registration required.

Pay Now

Create an account to be able to use extended features.

Register Now

The Bella Vista Water District is excited to offer residents an easy and convenient method to view and pay their water bills online.

This is a fee-based service. A service fee of **\$2.95** for credit card payments up to \$300.00. There is a **\$0.95** service fee for e-checks of any amount. (ACH/EFT).



Fast and Easy

No registration is required for "One Time Pay," the fastest way to pay online and confirm payment.



Safe and Secure

Your information is kept confidential, secure, and backed by the highest security standards.



Eco-Friendly

Paying online reduces paper use and is an easy way to help the environment.



[Sign In](#)

[Contact Us](#)

[← Return to previous page](#)

Please Locate Your Account

Water

Search our files for your invoices using the fields below. Required fields are marked with a *.
[Need help finding your invoice?](#)

Account Number *

Billing Address *

[Search Invoices](#)

Need Help?

You may reach us at (530) 241-1085.

[← Return to previous page](#)

Search Results

Please review your results below and select invoices to Pay. [Click here](#) if you would like to search again.

Bill No.	Account No.	Owner	Due Date	Bill Total	Balance Due	
617999	[REDACTED]	[REDACTED]	9/23/2020	\$254.28	\$0.00	View Only > Related Invoices Remind Me
610622	[REDACTED]	[REDACTED]	7/23/2020	\$171.68	\$0.00	View Only > Related Invoices Remind Me
606274	[REDACTED]	[REDACTED]	6/10/2020	\$93.04	\$0.00	View Only > Related Invoices Remind Me
603252	[REDACTED]	[REDACTED]	5/25/2020	\$92.03	\$0.00	View Only > Related Invoices Remind Me
595807	[REDACTED]	[REDACTED]	3/24/2020	\$69.19	\$0.00	View Only > Related Invoices Remind Me

Showing 6 to 10 of 12 entries

[Previous](#) [Next](#)

ATTACHMENT E

DISTRICT WATER SHORTAGE PLAN

- E.1 BVWD Water Shortage Contingency Plan**
- E.2 WSCP Mandatory Prohibitions**

ATTACHMENT E.1

**Bella Vista Water District
Water Shortage Contingency Plan**

WATER SHORTAGE CONTINGENCY PLAN

FOR

BELLA VISTA WATER DISTRICT

Revised June 2021

Prepared for:

Bella Vista Water District



Prepared By:

Provost & Pritchard Consulting Group



Table of Contents

1 - PURPOSES AND PRINCIPLES OF PLAN 1

2 - PROCEDURES FOR CONDUCTING ASSESSMENT 2

 2.1 Decision Making Process 2

 2.2 Data Inputs and Assessment Methodology 2

3 - WATER SHORTAGE STAGES 7

4 - SHORTAGE RESPONSE ACTIONS 8

 4.1 Response Actions by Water Shortage Stage 8

 4.2 Artificial Water Features 13

 4.3 Locally Appropriate Supply Augmentation Actions 13

 4.4 Locally Appropriate Demand Reductions 13

 4.5 Locally Appropriate Operational Changes 14

 4.6 Mandatory State Restrictions 14

 4.7 Gap Between Supply and Demand 14

5 - COMMUNITY OUTREACH 16

 5.1 Current and Predicted Shortages 16

 5.2 Shortage Response Actions 16

6 - CUSTOMER COMPLIANCE AND ENFORCEMENT 18

7 - LEGAL AUTHORITY OF THE PLAN 19

 7.1 Declaring a Water Shortage Emergency 19

 7.2 Supplier Coordination 19

8 - REVENUE REDUCTIONS AND EXPENSE INCREASES 20

 8.1 Potential Revenue Reductions and Expense Increases 20

 8.2 Mitigation Actions 20

 8.3 Cost Compliance 21

9 - MONITORING AND REPORTING REQUIREMENTS 22

10 - MONITORING AND EVALUATING THE PLAN 23

List of Tables

Table 1: Water Shortage Contingency Plan Requirements 1

Table 2: Updated Stages of Water Shortage 7

1 - PURPOSES AND PRINCIPLES OF PLAN

The purpose of the Bella Vista Water District (BVWD or District) Water Shortage Contingency Plan (WSCP) is to provide a methodology for analyzing water supply reliability, establishing water shortage stages, identifying appropriate response actions, and documenting protocols for enforcing the WSCP. This WSCP was prepared according to requirements in Sections 10632 & 10635 of the California Water Code. **Table 1** below shows the required components of a WSCP, the relevant water code section, and where they are found in this document.

Table 1: Water Shortage Contingency Plan Requirements

Topic	CA Water Code Section	WSCP Section
Water Supply Reliability Analysis	WC 10632 (a.1)	Section 2
Annual Assessment Procedures	WC 10632 (a.2)	Section 2
Water Shortage Stages	WC 10632 (a.3)	Section 3 Table 2
Shortage Response Actions	WC 10632 (a.4) WC 10632 (b)	Section 4
Communication Protocols	WC 10632 (a.5)	Section 5
Compliance and Enforcement	WC 10632 (a.6)	Section 6
Legal Authorities	WC 10632 (a.7)	Section 7
Financial Consequences of WSCP	WC 10632 (a.8)	Section 8
Monitoring and Reporting	WC 10632 (a.9)	Section 9
WSCP Refinement Procedures	WC 10632 (a.10)	Section 10

The District first adopted a WSCP in 1992 and has updated it several times since then. This updated WSCP includes changes from the 2015 WSCP to meet new State requirements and better serve the District and its water users. All the water uses that are regulated or prohibited under this Plan are considered to be non-essential. Therefore, the continuation of such uses during times of water shortage or other emergency water supply conditions is deemed to constitute a waste of water, which subjects the offender(s) to penalties, as set forth in the WSCP.

2 - PROCEDURES FOR CONDUCTING ASSESSMENT

2.1 Decision Making Process

Regulatory Requirement

§10632(a.2.A) The written decision-making process that an urban water supplier will use each year to determine its water supply reliability.

§10632 (a.2.B) (iv) A defined set of locally applicable evaluation criteria that are consistently relied upon for each annual water supply and demand assessment.

In 2005, BVWD entered a long-term (25-year) renewal contract with the United States Bureau of Reclamation (USBR, Reclamation) (*Contract No. 14-06-200-851A-LTR1*) that authorizes the District to divert up to 24,578 AF annually, subject to shortage provisions, from the Sacramento River via the Central Valley Project (CVP). This is the primary water source for the District. However, Reclamation is often unable to deliver the full contract quantities due to hydrological conditions and environmental regulations. Therefore, the CVP allocations would serve as the primary determinant as to whether the District would expect to see a supply shortage. Traditionally March 1st marks the commencement of the water year for CVP supplies and is also the tentative date for the District to first consider implementing water shortage stages.

Additionally, several hydrologic datasets act as early predictors of the allocation the District can expect from Reclamation. These include the following:

1. Lake Shasta Reservoir Storage
2. Northern Sierra Precipitation and Snowpack
3. Sacramento Valley 40-30-30 Water Year Index
4. Shasta Lake Unimpaired Inflow
5. Regional and national drought indices (lower priority due to the general nature of their predictions)

Refer to the District's 2020 Drought Contingency Plan (Chapter 3 – Drought Monitoring Plan) for additional details on these data sources.

The District Engineer is responsible for collecting and analyzing various hydrologic datasets and assessing water demands versus anticipated supplies. The District Manager will be updated regularly, and the District Board of Directors will also be provided informative briefings at monthly Board meetings.

2.2 Data Inputs and Assessment Methodology

Current Year Demand

Regulatory Requirement

§10632 (a.2.B) (i) Current year unconstrained demand, considering weather, growth, and other influencing factors, such as policies to manage current supplies to meet demand objectives in future years, as applicable.

When assessing current demands, BVWD typically looks at the average of the last three years of unconstrained demand due to the requirements of the USBR M&I Water Shortage Policy. A “Normal Supply” is also defined as the average supply during the last three years of unconstrained supplies. As a result, years with water restrictions are not included in the average. When necessary, other considerations such as new growth, weather, etc. will be considered in estimating demand.

Quantification of Water Supply

Regulatory Requirement

§10632 (a.2.B) The key data inputs and assessment methodology used to evaluate the urban water supplier’s water supply reliability for the current year and one dry year.

§10632 (a.2.B) (iii) Current year available supply, considering hydrological and regulatory conditions in the current year and one dry year. The annual supply and demand assessment may consider more than one dry year solely at the discretion of the urban water supplier.

§10632 (a.2.B) (v) A description and quantification of each source of water supply.

BVWD maintains a Federal Water Contract with surface water diverted from the Sacramento River. In 2005, the District entered a long-term (25-year) Water Service renewal contract with the USBR (*Contract No. 14-06-200-851A-LTR1*) that authorizes the District to divert up to 24,578 AF from the Sacramento River supply via the Central Valley Project (CVP). USBR typically announces the initial allocation in February and may refine it over the next several months. The BVWD, also maintains a long-term transfer agreement with the Anderson-Cottonwood Irrigation District (ACID) for 1,536 AF/Y of CVP water, but this is reduced by 25% to 1,152 in Shasta Critical Years¹. Lastly, the District relies on groundwater pumping from 5 wells for a combined production of approximately 12 acre-feet/day but runs its wells on a limited basis producing less than 300 AF in a normal year.

In order to augment supply on behalf of agricultural customers that would otherwise be subjected to significant shortages, the District adopted a Supplemental Water Program in April of 2009. This program was prompted from frequent, unreliable water supplies as a result of the evolving regulatory environment. The goal of the Program is to acquire additional water supplies in shortage years on behalf of the District’s agricultural customers. Participation is on a voluntary basis, and therefore does not obligate the entire customer class. For example, those customers that have permanent crops may choose to participate, while others with pasture irrigation or annual row crops may choose to idle or fallow during shortages.

In the winter months and early spring, District staff reviews the CVP supply forecast, estimates demands, and determines the interest for additional water supplies in the upcoming water year. Once the Supplemental Water Program is activated, District staff then identifies, negotiates, and acquires needed supplies based on the applications received. The most likely source of supplemental water is from willing sellers that are also Central Valley Project contractors. Once a supply of water is obtained, the District then works with the appropriate agencies to obtain necessary approvals, schedule delivery, and transfer the water into the District.

¹ Shasta Critical Year is a term defined in specific water contracts. In general, a Shasta Critical Year occurs when the forecasted inflow to Shasta Lake for a particular water year is equal to or below 3.2 million acre-feet.

Existing Infrastructure Constraints**Regulatory Requirement**

§10632 (a.2.B) (iii) Existing infrastructure capabilities and plausible constraints.

The District has a water system that consists of three treated water storage tanks, nine pumping plants, a main treatment plant, five wells, and over 200 miles of pipeline ranging from 4-inch in diameter to 54-inches. All the water is pumped for delivery within the District's local service area. Additionally, surface water is pumped from the Sacramento River at the Wintu Pumping Plant, which is located outside of the District's boundary. From the Wintu Pumping Plant, water is sent to a Surge Tank and then to the Water Treatment Plant (WTP). All water previously described is used for domestic or agricultural purposes.

Plausible constraints could include the following:

1. Distribution System. As additional wells are added at the southern ends of the distribution system, there may be locally high head losses and limited conveyance capacity until the well water reaches larger transmission lines.
2. Water Storage. Water storage is currently limited. During certain times of the year the District only has several hours' worth of storage. Storage could also be problematic if the District is relying solely on its wells and day-to-day flows vary widely due to varying irrigation demands (i.e., large irrigators using water once or twice a week) or if a widespread power outage occurs (see the discussion under Power below). Storage could also become inadequate if the District installs more well capacity.
3. Power. Power outages due to downed power lines or Public Safety Power Shutoff (PSPS) events are a significant problem. The District does not have excess storage to meet demands during an outage if only well water is available. Nor does the District have backup generators at any of its wells. The District only has one portable generator; thus, it could only be used to run one well at a time. In addition, only three District wells have transfer switches for the connection of a portable generator.

Without additional storage, a power outage affecting multiple wells would require switching the District to surface water use until power could be restored. If the Water Treatment Plant has been off-line for more than a few days, it would require four to six hours to bring the plant back online and begin delivery of treated surface water into the distribution system.

Depending on water demands and storage volumes at the time that the outage occurs, the District could quickly exhaust its operational storage and some customers could experience reduced pressures or water outages.

4. Transfers of non-federal (non-project) water. Water transferred to the District from a source other than from another Central Valley Project contractor requires a Warren Act contract that is negotiated with Reclamation in order to utilize federal facilities for the conveyance of non-project water. Additionally, Reclamation requires a separate power contract for conveyance pumping of non-project water through federal facilities (i.e., the Wintu Pumping Plant) since it is not eligible for project use energy.

Seismic Risk Assessment

Legal Requirements

CWC 10632.5

(a) In addition to the requirements of paragraph (3) of subdivision (a) of Section 10632, beginning January 1, 2020, the plan shall include a seismic risk assessment and mitigation plan to assess the vulnerability of each of the various facilities of a water system and mitigate those vulnerabilities.

(b) An urban water supplier shall update the seismic risk assessment and mitigation plan when updating its urban water management plan as required by Section 10621.

(c) An urban water supplier may comply with this section by submitting, pursuant to Section 10644, a copy of the most recent adopted local hazard mitigation plan or multihazard mitigation plan under the federal Disaster Mitigation Act of 2000 (Public Law 106-390) if the local hazard mitigation plan or multihazard mitigation plan addresses seismic risk.

The District is located in an area of moderate seismicity, in the less seismically active western half of Shasta County. The county is subject to low and moderate ground shaking but has not sustained significant property damage or loss of life due to earthquakes in the past 120 years of records. However, the November 26, 1998 local magnitude ML 5.2 earthquake centered near Keswick Dam, west of the District, rocked the District's four-million-gallon water tank on its foundation causing bent anchor bolts and deformed washers. This was the largest recorded earthquake since USGS monitoring began in 1981 and is believed to have been the largest earthquake in the area since 1878.

The 2017 Shasta County Local Hazard Mitigation Plan states that earthquake activity in the area has not been a serious hazard in the past and is unlikely to become a serious hazard in the future. Soils in the area are not classified as being at risk of liquefaction so any earthquake damage would most likely be due to ground shaking rather than ground failure. The county enforces the California Building Code, which is applicable to new structures and based on predicted earthquake intensities, to minimize risk of loss of life and property damage due to seismic activity. The City of Redding has run earthquake scenarios calculating six percent Building Damage Ratios (repair cost divided by replacement cost, as a percentage) for older structures in the city's downtown and three percent for all other areas of the city. The District service area includes part of the northeastern part of Redding, but not downtown, corresponding to the three percent Building Damage Ratio. A copy of the Shasta County Local Hazard Mitigation Plan can be found at <https://www.co.shasta.ca.us/docs/libraries/public-works-docs/hmp-documents/shasta-county-hazard-mitigation-plan-november-2017.pdf>. A copy of the section of the Shasta County Local Hazard Mitigation Plan pertaining to seismic risk ("Section 4.34 Earthquake") is included in **Appendix R** of the 2020 Urban Water Management Plan.

All of the District's pump stations, wells, treatment facilities, and its main office have been constructed to meet California's earthquake standards. Nearly all of the facilities either have been extensively modified or built since 1990 to meet existing earthquake standards.

In 2000, the District completed seismic improvements on its four-million-gallon storage tank. The Improvements included the installation of sixty 2-inch anchor bolts and strengthened anchor bolt chairs to bring the tank installation up to the current AWWA tank design standards. In 2015, the District performed seismic improvements on the Surge Tank on Hilltop Drive to also bring that

tank installation up to the current ANSI/AWWA D100 Standard for steel tank design. The Improvements on the Surge Tank included the installation of thirty-five 2-inch anchor bolts and strengthened anchor bolt chairs.

3 - WATER SHORTAGE STAGES

Regulatory Requirement

§10632 (a.3.A) Six standard water shortage levels corresponding to progressive ranges of up to 10, 20, 30, 40, and 50 percent shortages and greater than 50 percent shortage. Urban water suppliers shall define these shortage levels based on the suppliers’ water supply conditions, including percentage reductions in water supply, changes in groundwater levels, changes in surface elevation or level of subsidence, or other changes in hydrological or other local conditions indicative of the water supply available for use. Shortage levels shall also apply to catastrophic interruption of water supplies, including, but not limited to, a regional power outage, an earthquake, and other potential emergency events.

As outlined in the new Water Code requirements (10632 a & b.), Water Shortage Contingency Plans must include or be adapted to the six standard water shortage levels, which correspond to the progressive ranges of <10%, 10-20%, 20-30%, 30-40%, 40-50%, and 50+%. These six stages are described in **Table 2**. Stages 5 and 6 can be declared for a short-term (<45 days) or long-term (>45 days) shortage. The various Response Actions that correspond with these stages are addressed in **Section 4** of this plan.

Table 2: Updated Stages of Water Shortage

Stage	Supply Reduction	Water Supply Condition
1	0%-10%	Normal Water Supply (90% to 100% of Normal Water Production)
2	10%-20%	Moderate Water Shortage (80% to 90% of Normal Water Production)
3	20%-30%	Severe Water Shortage (70% to 80% of Normal Water Production)
4	30%-40%	Extreme Water Shortage (60% to 70% of Normal Water Production)
5A	40%-50%	Critical I Water Shortage-Short Term (50% to 60% of Normal Water Production)
5B	40%-50%	Critical I Water Shortage-Long Term (50% to 60% of Normal Water Production)
6A	50+%	Critical II Water Shortage-Short Term (Less than 50% of Normal Water Production)
6B	50+%	Critical II Water Shortage-Long Term (Less than 50% of Normal Water Production)

Notes:

1 – Short term conditions occur for 45 days or less and may be attributed to infrastructure, water quality, or power issues, as well as hydrologic conditions. Long-term conditions are greater than 45 days and are typically due to hydrologic conditions.

2 – “Normal Water Production” refers to the average water production during the last 3 years with unconstrained supplies.

4 - SHORTAGE RESPONSE ACTIONS

4.1 Response Actions by Water Shortage Stage

Regulatory Requirement

§10632 (a.4) Shortage response actions that align with the defined shortage levels

The existing response actions have been reviewed and updated for thoroughness, compliance with existing regulations, and applicability during potential times of drought, most recently observed in 2015 and 2021. The declaration of a Stage is made by the District's General Manager or his/her designee and subject to ratification by the District's Board of Directors in a regular or special session. Typically, all the Response Actions are enacted when a stage is declared; however, the District may adjust the required water use reductions or elect to exclude certain Response Actions when the water shortage stage is declared. Following are the standard Response Actions for each water shortage stage.

Stage 1. Below Normal Water Supply (90% to 100% of Normal Water Production)

Stage 1. Below Normal Water Supply is categorized with a possible reduction percentage of up to 10%. Response Actions may include:

- Water shall be used for beneficial purposes only; all unnecessary and wasteful uses of water are prohibited (*District Policy Manual Section 143*).
- Water shall not be applied to outdoor landscapes in a manner that causes runoff such that water flows onto adjacent property, non-irrigated areas, private and public walkways, roadways, parking lots, or structures. Care shall be taken not to water past the point of saturation.
- Free-flowing hoses are prohibited for all uses. Automatic shut-off devices shall be attached on any hose or filling apparatus in use.
- Leaking customer pipes or faulty sprinklers shall be repaired within five (5) working days or less if warranted due to the severity of the problem or shall not be utilized until repaired.
- All pools, spas, and ornamental fountains/ponds shall be equipped with a recirculation pump and shall be constructed to be leakproof.
- Swimming pool and spa covers encouraged to prevent evaporative water loss.
- Pool draining and refilling shall be allowed only for health, maintenance, or structural considerations.
- Washing streets, parking lots, driveways, or sidewalks, except as necessary for health, aesthetic, or sanitary purposes, is prohibited.
- To reduce evaporation, between March 1 and October 31 the use of sprinkler irrigation systems for all landscape irrigation systems shall be limited to be between the hours of 7:00 p.m. and 9:00 a.m. Sprinkler irrigation systems may be run outside of these hours for testing, but not for more than 15 minutes per cycle and only long enough to verify proper operation and make sprinkler adjustments.
- Irrigated landscaped areas shall include efficient irrigation systems (e.g., drip irrigation, timed sprinklers, rain sensors, low-flow spray heads, etc.).
- Use of potable water for the irrigation of turf or high-water use plants within public street medians and parkways is prohibited.

Stage 2. Moderate Water Shortage (80% to 90% of Normal Water Production)

Stage 2. Moderate Water Shortage is categorized with a possible reduction percentage of 10-20%. All Stage 1 Response Actions are required plus the following:

- Reduce water use by the following specified percentages: Residential and Rural by 10-20%, Multi-family and Public/Institutional customers by 10-20%, commercial customers by 5-10%, and Landscape Irrigation by 15-25%.
- Customers with “smart” irrigation timers or controllers are asked to set their controllers to achieve 90 to 95% of the evapotranspiration (ET) rate.
- Eating or drinking establishments, including but not limited to: Restaurants, cafes, cafeterias, bars, or other public places where food or drink are served and/or purchased shall serve water only upon request.
- Operators of hotels and motels shall offer patrons the option of not having their towels and linens washed daily.
- Water use overuse penalties may be implemented.
- Users of construction meters and fire hydrant meters will be monitored for efficient water use.

Penalties: Water use exceeding the customer’s water shortage allocation will be charged at the applicable overuse penalty rate. Any customer in violation of Stage 2 requirements (other than exceeding their water allocation) shall be first notified of the regulations and warned of the penalty associated with continued violation. If the violation is not corrected in a timely manner, any continued violation of mandatory Stage 2 requirements after notice and warning is provided shall be punishable by an administrative fine per day or per occurrence as set in Appendix A of the District’s Policy Manual.

Stage 3. Severe Water Shortage (70% to 80% of Normal Water Production)

Stage 3. Severe Water Shortage is categorized with a possible reduction percentage of 20-30%. All the Response Actions in Stage 2 are required plus the following new Response Actions:

- Outdoor irrigation of ornamental landscapes and turf with potable water shall be limited to 3 days a week. Customers whose street addresses end with an odd number may water on Wednesday, Friday, and Sunday. Customers whose street addresses end with an even number may water on Tuesday, Thursday, and Saturday.
- The application of potable water to outdoor landscapes during or within 48 hours after rainfall of 0.20 inches or more is prohibited.
- Flushing of water mains, sewers, or fire hydrants is prohibited except for emergencies and essential operations.
- Water overuse penalties may be implemented; or modified, if already implemented a previous stage.
- Motor vehicles and equipment shall be washed only with buckets or with hoses equipped with automatic shutoff nozzles.

The following Response Actions replace previous less stringent actions:

- Leaking customer pipes or faulty sprinklers shall be repaired within two (2) working days or less if warranted due to the severity of the problem.

- Reduce water use by the following specified percentages: Residential and Rural by 20-30%, Multi-family and Public/Institutional customers by 20-30%, commercial customers by 20%, and Landscape Irrigation by 25-35%.
- Customers with “smart” irrigation timers or controllers are asked to set their controllers to achieve 75% of the evapotranspiration (ET) rate. Drip irrigation systems are excluded from this requirement.

Penalties: Water use exceeding the customer’s water shortage allocation will be charged at the applicable overuse penalty rate. Any customer in violation of Stage 3 requirements (other than exceeding their water allocation) shall be first notified of the regulations and warned of the penalty associated with continued violation. If the violation is not corrected in a timely manner, any continued violation of mandatory Stage 3 requirements after notice and warning is provided shall be punishable by an administrative fine per day or per occurrence as set in Appendix A of the District’s Policy Manual.

Stage 4 Extreme Water Shortage (60% to 70% of Normal Water Production)

Stage 4. Extreme Water Shortage is categorized with a possible reduction percentage of 30-40%. All the Response Actions in Stage 3 are required plus the following new Response Actions:

- Water use for ornamental ponds, fountains, or other ornamental water feature for aesthetic purposes is prohibited except where necessary to support aquatic life.
- The application of potable water to driveways and sidewalks is prohibited.
- The installation of new turf or landscaping is prohibited.
- Irrigation of ornamental turf with potable water on public street medians is prohibited.
- Water use or overuse penalties may be implemented; or modified, if already implemented a previous stage.
- New connections to the District’s water distribution system will be allowed but their water use shall be restricted to the minimum requirements for personal health and safety.

The following Response Actions replace previous less stringent actions:

- Leaking customer pipes or faulty sprinklers shall be repaired within 24 hours or less if warranted due to the severity of the problem.
- Reduce water use by the following specified percentages: Residential and Rural by 30-40%, Multi-family and Public/Institutional customers by 30-40%, commercial customers by 30%, and Landscape Irrigation by 35-50%.

Penalties: Water use exceeding the customer’s water shortage allocation will be charged at the applicable overuse penalty rate. Any customer in violation of Stage 4 requirements (other than exceeding their water allocation) shall be first notified of the regulations and warned of the penalty associated with continued violation. If the violation is not corrected in a timely manner, any continued violation of mandatory Stage 4 requirements after notice and warning is provided shall be punishable by an administrative fine per day or per occurrence as set in Appendix A of the District’s Policy Manual.

Stage 5A Critical I Water Shortage Short-Term (50% to 60% of Normal Water Production)

Stage 5A Critical I Water Shortage is categorized with a possible reduction percentage of 40-50%. A short-term declaration is for water shortage conditions expected for a duration of 45 days or less. All the Response Actions in Stage 4 are required plus the following new Response Actions:

- Water use for ornamental ponds and fountains is prohibited.
- No potable water from the District's system shall be used for construction purposes including but not limited to dust control, compaction, or trench jetting.

The following Response Actions replace previous less stringent actions:

- Leaking customer pipes or faulty sprinklers shall be repaired within 24 hours. Water service will be suspended until repairs are made.
- Reduce water use by the following specified percentages: Residential and Rural 40% to 50% or more, Multi-family and Public/Institutional customers reduce water use by 40% to 50% or more, commercial customers by 30%, and Landscape Irrigation by 50%.
- Water for flow testing and construction purposes from water agency fire hydrants and blow-offs is prohibited.
- Water overuse penalties will be implemented.

Penalties: Water use exceeding the customer's water shortage allocation will be charged at the applicable overuse penalty rate. Any customer in violation of Stage 5 requirements (other than exceeding their water allocation) shall be first notified of the regulations and warned of the penalty associated with continued violation. If the violation is not corrected in a timely manner, any continued violation of mandatory Stage 5 requirements after notice and warning is provided shall be punishable by an administrative fine per day or per occurrence as set in Appendix A of the District's Policy Manual.

Stage 5B Critical I Water Shortage Long-Term (50%-60% of Normal Water Production)

Stage 5B Critical II Water Shortage is categorized with a possible reduction percentage of 40-50%. A long-term declaration is for water shortage conditions expected for a duration of 45 days or more. All the Response Actions in Stage 5A are required plus the following that replace previous less stringent actions:

- Motor vehicles and equipment shall be washed only at commercial establishments that use recycled or reclaimed water.

Penalties: Water use exceeding the customer's water shortage allocation will be charged at the applicable overuse penalty rate. Any customer in violation of Stage 5 requirements (other than exceeding their water allocation) shall be first notified of the regulations and warned of the penalty associated with continued violation. If the violation is not corrected in a timely manner, any continued violation of mandatory Stage 5 requirements after notice and warning is provided shall be punishable by an administrative fine per day or per occurrence as set in Appendix A of the District's Policy Manual.

Stage 6A Critical II Water Shortage Short-Term (less than 50% of Normal Water Production)

Stage 6A Critical II Water Shortage is categorized with a possible reduction percentage of 50+%. A short-term declaration is for water shortage conditions expected for a duration of 45 days or less. All the Response Actions in Stage 5B are required plus the following new Response Actions:

- Landscape irrigation is prohibited.

The following Response Actions replace previous less stringent actions:

- Leaking customer pipes or faulty sprinklers shall be repaired immediately. Water service will be suspended until repairs are made.
- Reduce water use by the following specified percentages: Residential and Rural by 50% or more, Multi-family and Public/Institutional customers by 50% or more, commercial customers by 30% or more, and Landscape Irrigation by 100%.
- Water use overuse penalties will be implemented; or modified, if already implemented a previous stage.
-

Penalties: Water use exceeding the customer's water shortage allocation will be charged at the applicable overuse penalty rate. Any customer in violation of Stage 6 requirements (other than exceeding their water allocation) shall be first notified of the regulations and warned of the penalty associated with continued violation. If the violation is not corrected in a timely manner, any continued violation of mandatory Stage 6 requirements after notice and warning is provided shall be punishable by an administrative fine of \$500.00 per day or per occurrence.

Stage 6B Critical II Water Shortage Long-Term (less than 50% of Normal Water Production)

Stage 6B Critical II Water Shortage is categorized with a possible reduction percentage of 50+%. A long-term declaration is for water shortage conditions expected for a duration of 45 days or more. All the Response Actions in Stage 6A are required plus the following new Response Actions:

- No commitments ("will serves") will be made to provide service for new water service connections.

Penalties: Water use exceeding the customer's water shortage allocation will be charged at the applicable overuse penalty rate. Any customer in violation of Stage 6 requirements (other than exceeding their water allocation) shall be first notified of the regulations and warned of the penalty associated with continued violation. If the violation is not corrected in a timely manner, any continued violation of mandatory Stage 6 requirements after notice and warning is provided shall be punishable by an administrative fine of \$500.00 per day or per occurrence.

4.2 Artificial Water Features

Regulatory Requirement

§10632 (a.10) For purposes of developing the water shortage contingency plan pursuant to subdivision (a), an urban water supplier shall analyze and define water features that are artificially supplied with water, including ponds, lakes, waterfalls, and fountains, separately from swimming pools and spas, as defined in subdivision (a) of Section 115921 of the Health and Safety Code.

Artificial water features, herein defined as ponds, lakes, waterfalls, fountains, and other water features for aesthetic purposes, are treated separately from swimming pools and spas in the Response Actions. Evaporation losses from swimming pools and spas can be reduced through the use of covers, yet this is generally not feasible with other artificial water features. Swimming pools can also provide an important source of cooling in the hot local climate.

4.3 Locally Appropriate Supply Augmentation Actions

Regulatory Requirement

§10632 (a.4.A) Locally appropriate supply augmentation actions.

The BVWD has a Water Service Contract with Reclamation for Central Valley Project water; however, it should be noted that while the District's water service contract with the Reclamation provides for rescheduling of water, the Reclamation has denied all of the District's requests to carry-over water from year to year, thus eliminating any safety net possible from storing wet year water for use in future dry years.

Additionally, the District maintains its long-term agreement with Anderson-Cottonwood Irrigation District (ACID); however, these allocations have the potential to be reduced by 25% under ACID's Water Settlement Contract with the Reclamation. As previously addressed, the BVWD has a sufficient water supply during normal and wet years; however, it is considerably disadvantaged during dry years as it relies almost exclusively on its CVP supply.

Groundwater pumping can account for a significant amount of the local supply as the five District wells may produce upwards of 12 acre-feet/day. This has the potential to decrease during particularly dry years. Use of groundwater in droughts is an important supply augmentation measure. Lastly, the District has relied on and participated in short-term water transfers; however, these opportunities are limited, particularly in dry years.

4.4 Locally Appropriate Demand Reductions

Regulatory Requirement

§10632 (a.4.B) Locally appropriate demand reduction actions to adequately respond to shortages.

The District has taken into consideration specific social and geographical aspects of Shasta County in developing the Response Actions. For instance, the District is comprised mostly of large rural residential parcels, and consequently, the vast majority of water is used outdoors, much more so than in other urban agencies. As a result, most of the Response Actions focus on outdoor water use. In addition, due to the very high summer temperatures in the region, restrictions are placed on daytime irrigation.

4.5 Locally Appropriate Operational Changes

Regulatory Requirement

§10632 (a.4.C) Locally appropriate operational changes.

During normal water years, demands are primarily met with surface water and supplemented with well water, as needed. During a critical drought, this would switch to providing water primarily from wells that are supplemented with surface water. This would be a major operational change and require daily visits to the wells for O&M versus once or twice weekly during a normal year. All the wells also have iron and manganese removal systems that require filter backwashing on a regular basis and periodic removal of settled sludge. Thus, with higher groundwater use in a drought, wellhead treatment operations will require substantially more labor.

4.6 Mandatory Restrictions

Regulatory Requirement

§10632 (a.4.D) Additional, mandatory prohibitions against specific water use practices that are in addition to state-mandated prohibitions and appropriate to the local conditions.

In 2015 the State Water Resources Control Board released mandatory water restrictions during the drought that included the following:

- No irrigation with potable water of ornamental turf on public street medians
- No irrigation with potable water outside of newly constructed homes and buildings not in accordance with emergency regulations or other requirements established by the Building Standards Commission and the Department of Housing and Community Development
- No washing of sidewalks and driveways with potable water
- No runoff allowed when irrigating with potable water
- Hoses must have an automatic shutoff nozzle when washing cars
- No use of potable water in decorative water features that do not recirculate the water
- No outdoor irrigation during and within 48 hours following measurable rainfall
- Restaurants may not serve water to customers unless they request it
- Hotels and motels must offer guests the option to not have their linens and towels laundered daily and prominently display this option in each room

The District's response actions (see Section 4.1) include all these measures and go beyond them with other measures related to: beneficial water use, timely leak repair, swimming pools and spas, smart irrigation systems, dedicated irrigation days, construction water, water system flushing, penalties for violations of the required response actions, water overuse penalties, and restrictions on new water connections.

4.7 Gap Between Supply and Demand

Regulatory Requirement

§10632 (a.4.E) For each action, an estimate of the extent to which the gap between supplies and demand will be reduced by implementation of the action.

Each water shortage stage includes response actions that are estimated to provide the needed water savings required. These response actions have also been refined over time and proven to generally provide the reductions needed. If prohibitions at any stage do not result in the required water savings, the District can simply go to the next stage. The District also has flexibility to enforce only some of the response actions in a stage, providing the opportunity to make small adjustments when needed.

5 - COMMUNITY OUTREACH

5.1 Current and Predicted Shortages

Regulatory Requirement

§10632 (a.5) Communication protocols and procedures to inform customers, the public, interested parties, and local, regional, and state governments, regarding, at a minimum, all the following:
(A) Any current or predicted shortages as determined by the annual water supply and demand assessment described pursuant to Section 10632.1.

The BVWD has identified the four following categories as significant points of discussion, regarding current and predicted drought shortages.

- Various causes of drought in the area
- Regulatory impacts on water supplies
- Drought impacts on water supplies
- Constraints on water transfers and exchanges

Additionally, the District will utilize the drought indices and hydrologic datasets outlined **Section 2**. Should a potential shortage be anticipated, the public and BVWD customers will be notified via public notices, announcements on the District's web page (www.bvwd.org), and in their bimonthly billings and warned of the potential for a drought declaration and water conservation measures.

5.2 Shortage Response Actions

Regulatory Requirement

§10632 (a.5.B) Any shortage Response Actions triggered or anticipated to be triggered by the annual water supply and demand assessment described pursuant to Section 10632.1.
Any other relevant communications.

The District's Board of Directors will be kept informed of water shortage conditions to enable them to make timely and appropriate decisions on the following actions:

- Coordination with customers on the development and implementation of plans
- Frequent assessment of water shortage status
- Adoption of resolutions to change water storage stages
- Declaration of a water shortage emergency
- Adoption of an Emergency Water Reduction Plan

These actions are communicated to District customers by way of billing inserts, newspaper advertising, on the District's webpage (www.bvwd.org), and by verbal communication as District staff and personnel interact with the customers.

5.3 Plan Availability

Regulatory Requirement

§10632 (c) The urban water supplier shall make available the water shortage contingency plan prepared pursuant to this article to its customers and any city or county within which it provides water supplies no later than 30 days after adoption of the water shortage contingency plan.

The District will make copies of its Water Shortage Contingency available to its customers, the City of Redding, and Shasta County no later than 30 days after adoption of the plan.

6 - CUSTOMER COMPLIANCE AND ENFORCEMENT

Regulatory Requirement

§10632 (a.6) For an urban retail water supplier, customer compliance, enforcement, appeal, and exemption procedures for triggered shortage Response Actions as determined pursuant to Section 10632.2.

The BVWD Board of Directors, and more specifically the District Engineer, will be responsible for evaluating available data on a consistent basis and adequately determining/implementing the appropriate Response Actions, dependent of the Water Shortage Stage in place.

Section 4 – Shortage Response Actions outlines the various water conservation measures during each water shortage stage, as well as the various enforcements. The penalties for each stage are also outlined in this section and in Appendix A of the District Policy Manual and can vary significantly depending on the activated Water Shortage Stage.

Customers may request an exemption or variance or may appeal enforcement with the General Manager in accordance with the District’s Policy Manual. The District’s specific policies are outlined below.

Exception and/or Variance Process. Designated staff may, in writing, grant temporary variances for prospective uses of water after determining that, due to unusual circumstances, to fail to grant such variance would cause an emergency or hardship condition affecting health, sanitation, or fire protection of the applicant or the public. The Board of Directors shall ratify or revoke any such variance or adjustment at its next scheduled meeting. Any such variance or adjustment so ratified may be revoked by later action of the Board of Directors. No such variance shall be retroactive or otherwise justify any violation of the water use restrictions occurring prior to issuance of temporary variance. It must be recognized that due to a declared water shortage emergency, the District has limited ability to grant exceptions and/or variances to the Water Shortage Contingency Plan.

7 - LEGAL AUTHORITY OF THE PLAN

Regulatory Requirement

§10632 (a.7.A) A description of the legal authorities that empower the urban water supplier to implement and enforce its shortage Response Actions specified in paragraph (4) that may include, but are not limited to, statutory authorities, ordinances, resolutions, and contract provisions.

This WSCP adheres with the California Water Code 10632. This document is also required by State law as outlined in the Water Code, which states that, “Every urban water supplier shall prepare and adopt a water shortage contingency plan as part of its urban water management plan...” (WC 10632). As an established California Water District, BVWD has the authority to implement the WSCP, declare water shortages, and implement shortage response actions including statutory authorities, ordinances, resolutions, and contract provisions.

7.1 Declaring a Water Shortage Emergency

Regulatory Requirement

§10632 (a.7.B) A statement that an urban water supplier shall declare a water shortage emergency in accordance with Chapter 3 (commencing with Section 350) of Division 1.

The BVWD will follow the protocols outlined in this Plan should it become necessary to declare a water shortage emergency. The process will follow the pertinent sections of the California Water Code and be noticed for a public hearing, typically at a Board of Directors meeting.

7.2 Supplier Coordination

Regulatory Requirement

§10632 (a.7.C) A statement that an urban water supplier shall coordinate with any city or county within which it provides water supply services for the possible proclamation of a local emergency, as defined in Section 8558 of the Government Code.

The District Manager or designated staff will be available and responsible for coordinating with City and County officials within the District’s service area should there be a necessary proclamation for a local water emergency.

8 - REVENUE REDUCTIONS AND EXPENSE INCREASES

The various revenue sources available to the District during droughts include, but are not limited to water sales, system connection fees, interest income, special assessments, reserves, and other non-operating revenues, such as grant funding when available. In addition, there may be special outside funding sources made available to water agencies during a water emergency (e.g., Stages 4 through 6).

8.1 Potential Revenue Reductions and Expense Increases

Regulatory Requirement

§10632 (a.8) A description of the financial consequences of, and responses for, drought conditions, including, but not limited to, all of the following:
 (A) A description of potential revenue reductions and expense increases associated with activated shortage Response Action described in paragraph (4)

Potential revenue reductions may include, but are not limited to:

- Decreased water sales to residential, rural, commercial, and public/institutional users
- Decreased water sales to agricultural water users

Potential expense increases may include, but are not limited to:

- Higher CVP water costs due to reduced water deliveries
- Higher costs for increased groundwater production and treatment
- Higher costs for pumping groundwater from greater depths
- Purchases of higher priced transfer water

8.2 Mitigation Actions

Regulatory Requirement

§10632 (a.8.B) A description of mitigation actions needed to address revenue reductions and expense increases associated with activated shortage Response Actions described in paragraph (4).

Several mitigation actions are specifically tailored to offset or soften the financial impact of drought to the District including the following:

1. M&I Rate Stabilization Fund. The District currently maintains a specific M&I Rate Stabilization Fund to help mitigate the revenue impacts of a prolonged drought. This fund has been built up by placing a small portion of urban water user fees into this fund during normal supply years to help offset higher costs during droughts.
2. Supplemental Water Program. This voluntary program allows agricultural water users to purchase supplemental water supplies secured by the District on behalf of participants. This program is only offered during water shortages and the water costs are always higher than typical District costs. This water is sold at cost to participating Agricultural customers ensuring that the District does not lose money on the transaction.

8.3 Cost of Compliance

Regulatory Requirement

§10632 (a.8.C) A description of the cost of compliance with Chapter 3.3 (commencing with Section 365) of Division 1.

In a drought emergency, the District anticipates that there will be expenses incurred that would not otherwise be incurred in a normal water year. These include:

- Higher water costs associated with the cost of water transfers or water purchases to augment its water supplies,
- Increased operational and maintenance expenses associated with running its wells more that they are run in a normal year,
- Costs for special notifications to its customers (e.g., printing and mailing of special notices, publishing notices in the paper, advertising using radio or television),
- Costs for special programming of its billing software to implement drought charges and penalties,
- Payroll costs for additional staff or staff overtime to handle a higher-than-normal volume of customer service requests,

In a drought emergency, the District also anticipates that revenues may decrease due to a reduction in water sales.

The District's rate schedules the volumetric rates accurately reflect the unit cost for the production, treatment, and distribution of water to its customers. This means that the reductions in revenues associated with reductions in demand are offset by similar reductions in operational costs. In addition, the District's Supplemental Water Program for its agricultural customers passes through the full costs for the acquisition and delivery of water purchased for agricultural use. Higher water expenses associated with the production of more well water, water transfers, and water purchases are not passed through to the District's M&I customers. Instead, the District maintains a M&I Rate Stabilization Fund that can be tapped to cover increased expenses.

In water shortage emergencies, at Stages 2 and above, the District may impose overuse penalty charges. The intent of these charges is to deter the overuse of water (use in excess of customer allocations). The revenues generated from the overuse charges are used to help offset the increased expenses.

Based on the District's experience during the 2015 drought, the combined effect of having water rates that accurately reflect water costs, passing costs for supplemental agricultural water through to the agricultural water users, having a M&I Rate Stabilization Fund, and the revenues generated from overuse charges the District is well situated to comply with Chapter 3.3 without unacceptable use of existing reserves.

9 - MONITORING AND REPORTING REQUIREMENTS

Regulatory Requirement

§10632 (a.9) For an urban retail water supplier, monitoring and reporting requirements and procedures that ensure appropriate data is collected, tracked, and analyzed for purposes of monitoring customer compliance and to meet state reporting requirements.

The BVWD currently, and historically, has always been in compliance with the state reporting requirements. The District uses meters to monitor all of the District's water deliveries, which assists in assuring customer compliance. Additionally, the District maintains a protocol for receiving and addressing complaints of non-compliance and misuse.

The procedures for monitoring reductions throughout the six different water shortage stages are outlined below:

1. In normal water supply conditions (Stage 1) production and pumping totals are reported monthly to the District Engineer.
2. During Stage 2, 3, or 4 water shortage conditions, weekly production and pumping amounts are reported to the District Engineer to compare the weekly data to the targets to verify that reduction goals are being met.
3. During Stage 5a, 5b, 6a, or 6b water shortage, a daily production and pumping report is provided to the District Engineer to verify that goals are being met.

10 - MONITORING AND EVALUATING THE PLAN

Regulatory Requirement

§10632 (a.10) Reevaluation and improvement procedures for systematically monitoring and evaluating the functionality of the water shortage contingency plan in order to ensure shortage risk tolerance is adequate and appropriate water shortage mitigation strategies are implemented as needed.

The District first adopted its WSCP in 1992 and has revised and re-adopted it several times to incorporate refinements and improvements. In addition, this WSCP incorporates important lessons learned during the historic drought of 2013-2015. The WSCP will be re-evaluated at least every five years and at the end of each drought period to assess its performance. If deemed necessary, it will be modified and improved based on lessons learned. The Plan may also be updated in the middle of a drought year if needed.

ATTACHMENT E.2

**Bella Vista Water District
Water Shortage Contingency Plan – Table of Mandatory Prohibitions**

Water Shortage Contingency – Mandatory Prohibitions

Customer Actions		Stage 1	Stage 2	Stage 3	Stage 4	Stage 5		Stage 6	
						ST	LT	ST	LT
Water Waste	Water shall be used for beneficial uses only; all unnecessary and wasteful uses of water are prohibited (District Policy Manual Section 143).	✓	✓	✓	✓	✓	✓	✓	✓
	Water shall not be applied to outdoor landscapes in a manner that causes runoff such that water flows onto adjacent property, non-irrigated areas, private and public walkways, roadways, parking lots, or structures. Care shall be taken not to water past the point of saturation.	✓	✓	✓	✓	✓	✓	Landscape Irrigation is Prohibited	
	Free-flowing hoses for all uses shall be prohibited. Customers shall use automatic shutoff devices on any hose or filling apparatus in use.	✓	✓	✓	✓	✓	✓	✓	✓
	Leaking customer pipes or faulty sprinklers shall be repaired within the specified working days or less by Stage after due to the severity of the problem or shall not be utilized until repaired.	5 Days or Less	5 Days or Less	2 Days or Less	24 hours or Less	24 hours or Less		Immediately	
Pools and Water features	All pools, spas, and ornamental fountains/ponds shall be equipped with a recirculation pump and shall be constructed to be leakproof.	✓	✓	✓	✓	✓	✓	✓	✓
	Swimming pool and spa covers encouraged to prevent evaporative water loss.	✓	✓	✓	✓	✓	✓	✓	✓
	Potable water use for ornamental ponds and fountains is prohibited.					✓	✓	✓	✓
	Pool draining and refilling shall be allowed only for health, maintenance, or structural considerations.	✓	✓	✓	✓	✓	✓	✓	✓
	Water use for ornamental ponds, fountains, or other ornamental water feature for aesthetic purposes is prohibited except where necessary to support aquatic life.				✓				
	Water use for ornamental ponds and fountains is prohibited.					✓	✓	✓	✓
Buildings and Driveways	Washing streets, parking lots, driveways, or sidewalks, except as necessary for health, aesthetic or sanitary purposes, is prohibited.	✓	✓	✓					

Water Shortage Contingency – Mandatory Prohibitions

Customer Actions		Stage 1	Stage 2	Stage 3	Stage 4	Stage 5		Stage 6	
						ST	LT	ST	LT
	Application of potable water to driveways and sidewalks is prohibited				✓	✓	✓	✓	✓
Water Use Reductions	Residential and Rural Customers Reductions.	Up to 10%	10-20%	20-30%	30-40%	40-50%	40-50%	50% or more	50% or more
	Multi-family and Public Institutional Customers Reductions	Up to 10%	10-20%	20-30%	30-40%	40-50%	40-50%	50% or more	50% or more
	Commercial Customers Reductions	Up to 10%	5-10%	20%	30%	30%	30%	30% or more	30% or more
	Landscape Irrigation Reductions	Up to 10%	15-25%	25-35%	35-50%	50%	50%	100%	100%
	Water use exceedance tiered pricing or penalties may be implemented.			✓	✓				
	Water use exceedance tiered pricing or penalties will be implemented					✓	✓	✓	✓
Irrigation	To reduce evaporation, between March 1 and October 31 the use of sprinkler irrigation systems for all landscape irrigation systems shall be limited to be between the hours of 7:00 p.m. and 9:00 a.m. Sprinkler irrigation systems may be run outside of these hours for testing, but not for more than 15 minutes per cycle and only long enough to verify proper operation and make sprinkler adjustments.	✓	✓	✓	✓	✓	✓	Landscape Irrigation is Prohibited	
	Customers with “smart” irrigation timers or controllers are asked to set their controllers to achieve the specified % of the evapotranspiration (ET) rate.		90-95%	75%	75%	50-75%	50-75%		
	Irrigated landscaped areas shall include efficient irrigation systems (e.g., drip irrigation, timed sprinklers, rain sensors, low-flow spray heads, etc.).	✓	✓	✓	✓	✓	✓	Landscape Irrigation is Prohibited	

Water Shortage Contingency – Mandatory Prohibitions

Customer Actions		Stage 1	Stage 2	Stage 3	Stage 4	Stage 5		Stage 6	
						ST	LT	ST	LT
	Landscape irrigation limited to the days per week specified. Customers whose street addresses end with an odd number may water on Wednesday, Friday, and Sunday. Customers whose street addresses end with an even number may water on Tuesday, Thursday, and Saturday.			3 days per week	3 days per week	3 days per week	3 days per week		
	Application of potable water to outdoor landscapes during or within 48 hours after measurable rainfall is prohibited.			✓	✓	✓	✓		
Commercial	Eating or drinking establishments, including but not limited to: Restaurants, cafes, cafeterias, bars, or other public places where food or drink are served and/or purchased shall serve water only upon request.		✓	✓	✓	✓	✓	✓	✓
	Operators of hotels and motels shall offer patrons the option of not having their towels and linens washed daily.		✓	✓	✓	✓	✓	✓	✓
Equipment/Vehicle Washing	Motor vehicles or equipment shall be washed only with buckets or hoses with automatic shutoff nozzles.			✓	✓	✓			
	Motor vehicles and equipment shall be washed only at commercial establishments that use recycled or reclaimed water.						✓	✓	✓
Construction/New Service	Users of construction meters and fire hydrant meters will be monitored for efficient water use.		✓	✓	✓	No Construction Water			
	Water for flow testing and construction purposes from water agency fire hydrants and blow-offs is prohibited.					✓	✓	✓	✓
	Installation of new turf or landscaping is prohibited.				✓	✓	✓	✓	✓
	New connections to the District's water distribution system will be allowed but their water use shall be restricted to the minimum requirements for personal health and safety.				✓	✓	✓	✓	✓
	No potable water from the District's system shall be used for construction purposes including but not limited to dust control, compaction, or trench jetting.					✓	✓	✓	✓

Water Shortage Contingency – Mandatory Prohibitions

Customer Actions		Stage 1	Stage 2	Stage 3	Stage 4	Stage 5		Stage 6	
						ST	LT	ST	LT
	No commitments (“will serves”) will be made to provide service for new water service connections.								✓
Health & Safety	Flushing of water mains, sewers, or fire hydrants is prohibited except for emergencies and essential operations.			✓		✓	✓	✓	✓
	Water use shall be restricted so as to meet the minimum requirements for personal health and safety.					✓	✓	✓	✓

ATTACHMENT F

GROUNDWATER MANAGEMENT PLAN

Enterprise-Anderson Groundwater Sustainability Planning

Enterprise-Anderson Groundwater Sustainability Planning Project Brief

The Enterprise-Anderson Groundwater Sustainability Agency (EAGSA) has been formed to ensure the continued sustainability of the Enterprise and Anderson groundwater basins.



Membership and Primary Representatives

County of Shasta	Leonard Moty, County Supervisor
City of Anderson	Melissa Hunt, Vice-Mayor
City of Redding	Erin Resner, City Council Member
Bella Vista Water District	James Smith, Director
Anderson Cottonwood Irrigation District (ACID)	Brenda Haynes, President
Clear Creek Community Services District (CCCSD)	Irwin Fust, Director

Objectives

1. Comply with the Sustainable Groundwater Management Act (SGMA).
2. Ensure the continued sustainability of the Anderson and Enterprise Subbasins.
3. Develop and manage a Groundwater Sustainability Plan for the sustainable management of groundwater within the Enterprise and Anderson Subbasins of the Redding Area Groundwater Basin. Keep the complexity and costs as low as practicable.
4. Local management of groundwater based on local plan, local stakeholder input, and local values.

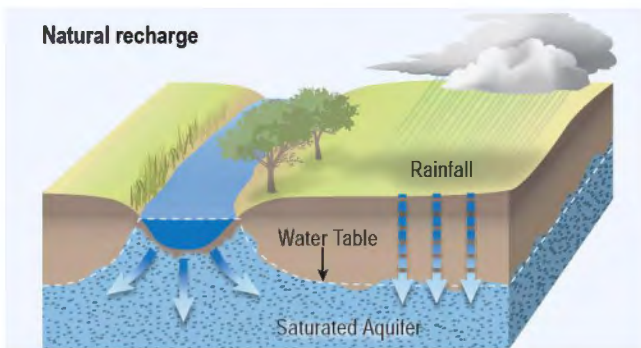

FOR MORE INFORMATION:

www.cityofredding.org/departments/public-works/eagsa.com

CONTACT:

Interested Parties List (Shasta County):

Charleen Beard | Supervising Engineer | 530-225-5661 | cbeard@co.shasta.ca.us

Sustainable Groundwater Management Act

- 1) What is the Sustainable Groundwater Management Act (SGMA)?
SGMA is a law requiring local agencies to sustainably manage groundwater use so it doesn't run out. While there are no known problems with the Redding Area Groundwater Basin, the creation of a Groundwater Sustainability Plan will help us work together to manage groundwater to support future community, wildlife, and economic prosperity.
- 2) What is a Groundwater Sustainability Plan (GSP)?
A GSP is a long term plan to manage groundwater by preventing: 1) continual lowering of groundwater levels, 2) decreased groundwater storage, 3) poor water quality, 4) settled or sunken land, and 5) depletion of rivers, streams, springs and wetlands.
- 3) What happens next?
A local engineering firm will collect, analyze and share groundwater data at public meetings. Local stakeholders will be invited to give input at future public meetings and EAGSA Board meetings regarding undesirable results and (if necessary) management actions. The EAGSA must finalize the Groundwater Sustainability Plan by January 31, 2022.

Enterprise-Anderson Groundwater Sustainability Plan

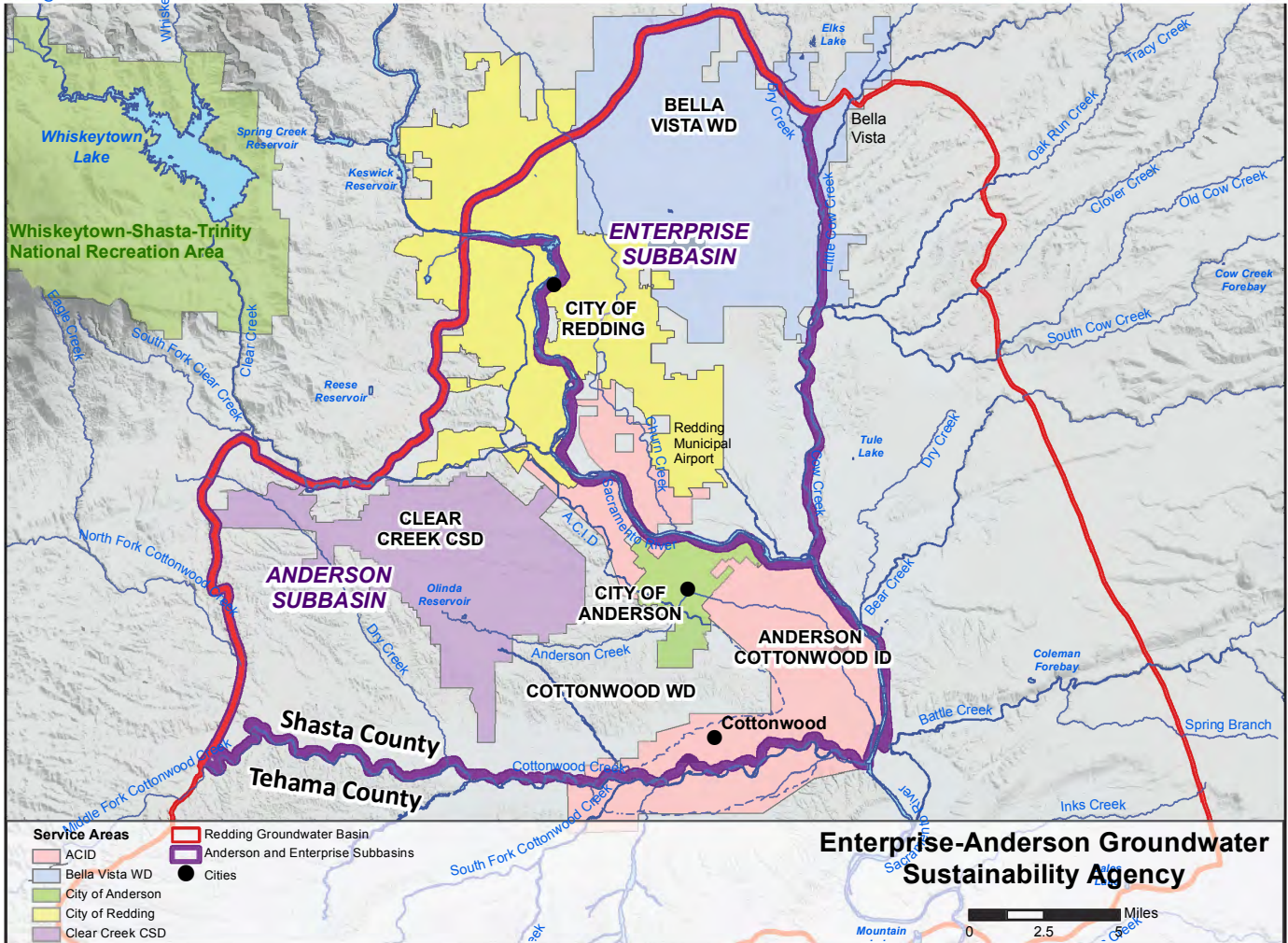

MYTH	FACT
The State of California is going to come in and manage our local wells and groundwater in the Redding Area – Enterprise and Anderson Subbasins.	Ownership and operation of wells connected to groundwater will remain intact. The locally led EAGSA will manage groundwater to meet the sustainability criteria as required by State law - but if the EAGSA fails to manage groundwater sustainably or if the EAGSA dissolves, the management of the groundwater could revert to the State.
Water meters are going to be required on private wells.	Neither the EAGSA nor the State are requiring meters for private wells.
I am going to get a bill for this Groundwater Sustainability Plan.	The EAGSA applied for and received a State grant to develop the Groundwater Sustainability Plans for the Enterprise and Anderson subbasins. Staffing costs are being borne by the six member agencies.
The State wants us to quantify our groundwater so they can take it and send it to the cities down south.	Having a GSP allows the locals to better manage and control the groundwater. If water rights holders choose to sell water down south, they would receive financial compensation and the sale would be temporary - there would not be any permanent change in rights to the groundwater. Additionally, environmental studies would be done before any sale took place to ensure that there are no adverse impacts to the environment or to neighboring wells, and all sales would be required to comply with the County Groundwater Ordinance.

Enterprise-Anderson Groundwater Sustainability Plan

Frequently Asked Questions

What is the Sustainable Groundwater Management Act (SGMA)?

SGMA is a law that requires local agencies to manage groundwater use to avoid undesirable results. All groundwater basins rated medium or high priority in Department of Water Resources Bulletin 118 must create a Groundwater Sustainability Agency (GSA) and a Groundwater Sustainability Plan (GSP), or the State will step in to manage groundwater. For more information visit:

http://www.water.ca.gov/cagroundwater/docs/sgma_brochure_jan_2015.pdf

What is the Enterprise Anderson Groundwater Sustainability Agency (EAGSA)? The EAGSA is comprised of Shasta County, City of Anderson, City of Redding, Anderson-Cottonwood Irrigation District, Bella Vista Water District, and Clear Creek Community Services District. The purpose of the EAGSA is to sustainably manage the Enterprise and Anderson subbasins and comply with SGMA, while keeping taxpayer costs down. The GSA formed with a memorandum of understanding on June 30, 2017 and plans to develop a GSP by January 31, 2022. The EAGSA is responsible for sustainably managing groundwater in the Enterprise and Anderson subbasins. The EAGSA will develop and implement a Groundwater Sustainability Plan (GSP).

Any local public agency that has water supply, water management, or land use responsibilities in a basin can become a GSA. Two GSA's cannot overlap. More GSA Information can be found at:

http://www.water.ca.gov/groundwater/sgm/pdfs/DWR_GSA_FAQ_2016-01-07.pdf

What is a Groundwater Sustainability Plan (GSP)?

A GSP is a long-term plan to sustainably manage groundwater and prevent undesirable results. The legislation lists six undesirable results: chronic lowering of groundwater levels, reduction of groundwater storage, seawater intrusion, degraded water quality, land subsidence, and depletion of interconnected surface water. Some undesirable results are non-issues in the Redding Basin, but all must be considered in the GSP. A guide for the GSP regulations can be found at:

http://water.ca.gov/groundwater/sgm/pdfs/GSP_Final_Regs_Guidebook.pdf

Is there a GSP for the Anderson and Enterprise Subbasins?

The EAGSA is working on the planning process now. The EAGSA has contracted Jacobs Engineering, Redding, CA to help study the groundwater basin and write the Groundwater Sustainability Plan. They have hired Kearns & West, a public outreach consultant to help stakeholders learn about their groundwater planning process and provide input to the plan. The EAGSA anticipates adopting the GSP prior to the 2022 deadline.

In the interim, groundwater is managed in accordance with the Coordinated AB3030 Groundwater Management Plan, adopted by the County in May 2007. The AB 3030 plan can be found at:

http://www.co.shasta.ca.us/index/pw_index/engineering/water_agency/ab3030_plan.aspx

Enterprise-Anderson Groundwater Sustainability Plan

How can we maintain local control of our groundwater?

Local agencies have formed the EAGSA to maintain local control of groundwater resources and management. If groundwater resources matter to you, please contact the EAGSA to join the Interested Parties list and contribute to sustainable groundwater management.

Does Shasta County have a groundwater problem?

There are no known problems with the Redding Area Groundwater Basin. The State has identified both Enterprise and Anderson subbasins as medium priority – meaning they are not in critical condition. This rating is mostly based on a heavy weighting of the criteria for population overlying the basin and its dependence on groundwater.

To view a complete map of all alluvial groundwater basins in California and their rating, go to <https://gis.water.ca.gov/app/gicima/>. On the upper left side of the page, click on the “Boundaries” tab and then check the box next to “CASGEM Groundwater Basin Prioritization”.

How could the Groundwater Sustainability Plan affect me?

Groundwater users will need to work together to make sure that the use of groundwater supplies are not consistently decreasing groundwater, taking too much water away from rivers and wetlands, nor making the ground settle or sink.

If you own a well or rent a home that uses a well, the sustainable management of groundwater could help ensure that your well doesn't go dry due to others' groundwater use. If you enjoy fishing, duck hunting or other water-related recreation, this sustainable management could ensure that groundwater use does not damage the wildlife habitat that is dependent on groundwater supplies. If you irrigate lands for agriculture or ranching, the EAGSA seeks to ensure that your groundwater supply will be predictable and reliable to sustain your and your family's livelihood. Studying the groundwater basin will improve our understanding of our groundwater supply and how to manage it to support future community and economic prosperity.

How do I get involved?

- Contact Shasta County Public Works at (530) 225-5661 to be added to the Interested Parties list for email updates on the planning process.
- Come to the EAGSA Board meetings each trimester in April, August, and December.
- Participate in Public Workshops in August/September 2019 and August/September 2020 to learn and provide your values, objectives, data needs, and alternatives for the future.
- Learn more at the EAGSA website: <https://www.cityofredding.org/departments/public-works/eagsa> where you can find Board meeting minutes and maps.
- Attend your local water supplier's Board meeting to learn more.

Enterprise Anderson Groundwater Sustainability Planning Schedule

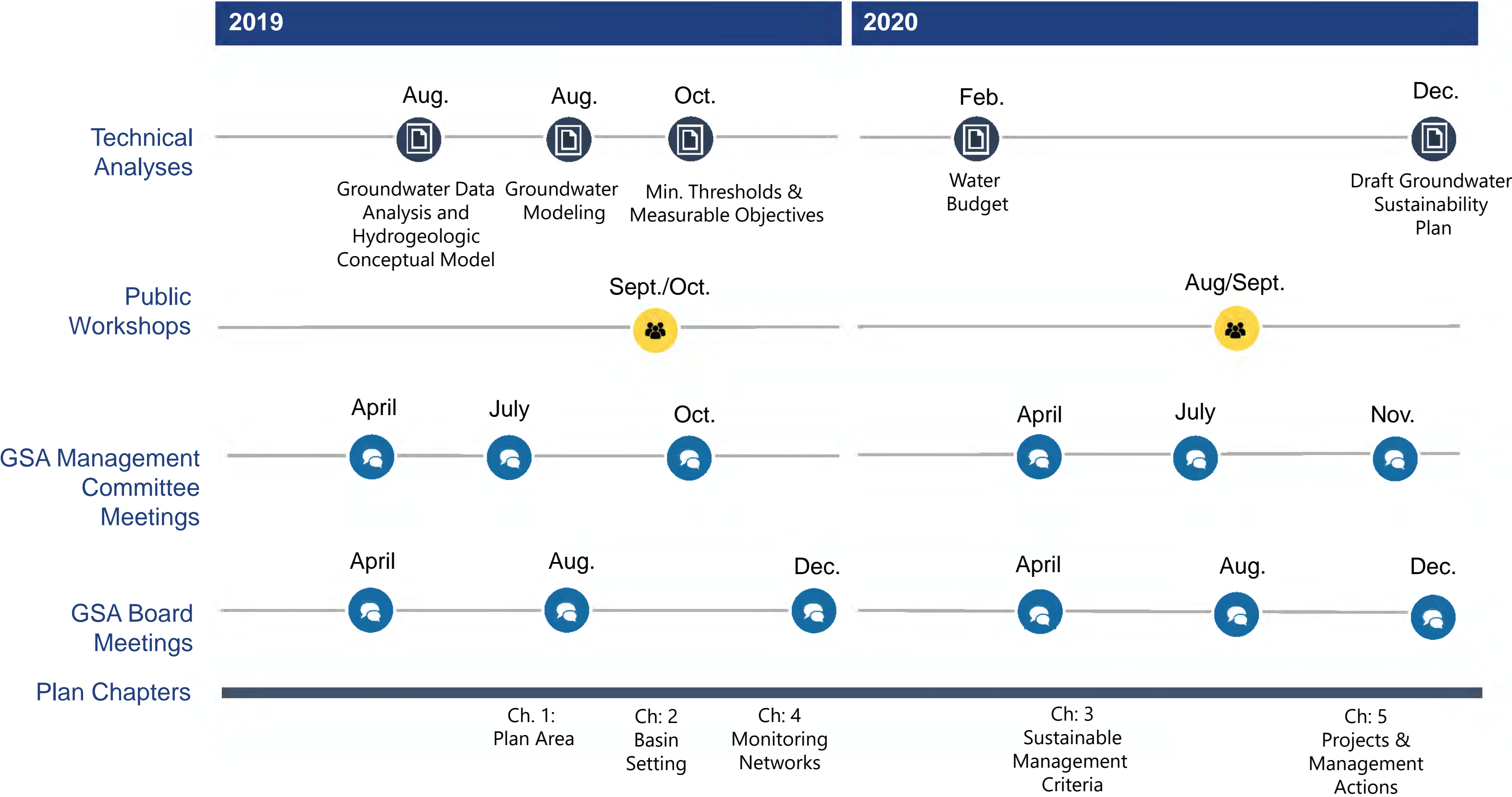

ATTACHMENT G

GROUNDWATER BANKING PLAN

Not Applicable

ATTACHMENT H

ANNUAL POTABLE WATER QUALITY REPORT - URBAN

BVWD 2020 Consumer Confidence Report

BELLA VISTA WATER DISTRICT

2020 CONSUMER CONFIDENCE REPORT

The District is pleased to present the 2020 Consumer Confidence Report. Our unvarying goal is to provide a safe and dependable supply of drinking water to all of our customers. Last year, as in years past, your tap water met all EPA and State drinking water health standards. Once again we are proud to report that our water system has never violated a maximum contaminant level or any other water quality standard.

(Este informe contiene información muy importante sobre su agua para beber. Favor de comunicarse Bella Vista Water District at 11368 East Stillwater Way Redding , California. 530-241-1085 para asistirlo en espanol.)

WHERE OUR WATER COMES FROM

In 2020 our water sources included surface water from the Sacramento River and some groundwater from our five wells. For the 2020 water year which included the months of March 2020 through February 2021, the District received a constrained Water Supply Allocation from the Central Valley Project. This allocation was 75% of historical use for municipal and industrial use and 50% for agricultural use driven by below average precipitation and slightly above average water storage. Although the District had a reduced supply in 2020, supply augmentation from water transfers and groundwater production allowed for a full water supply to meet all customer water demands without the imposition of any water shortage restrictions.

In 2020, surface water from the Sacramento River made up 91.5% of the treated water supply of approximately 3.51 billion gallons (10,785 acre-feet) compared with 94.8% of the treated water supply and 3.37 billion gallons (10,167 acre-feet) in 2019. The maximum daily flow through the Water Treatment Plant in 2020 was 22.1 million gallons (67.8 acre-feet) on August 10th. In 2020 the District captured and recycled approximately 185.5 million gallons (569 acre-feet) of filter backwash water, supplying approximately 4.8% of the treated water supply. This recycled water reduces the amount of water that the District diverts from the Sacramento River or pumps from groundwater wells and provides a much needed reliable source of water during shortages.

The District's wells draw from the [Redding Groundwater Basin, Enterprise Subbasin](#). The wells made up 3.7% of the total supply, or approximately 143.4 million gallons (440 acre-feet) in 2020 compared with 1.7% of the treated water supply and 56.7 million gallons (174 acre-feet) in 2019. The treatment process at each of the five wells consists of oxidation of iron and manganese using chlorine, followed by absorption of the iron and manganese oxides in pressure filters. Chlorine residual is carried through the entire process to aid in maintaining chlorine residual in the distribution system. No iron or manganese was detected in any of the treated well water samples collected in 2020. Well water is warmer than the treated surface water and has a different taste due to its higher mineral content. At times, the mixing of chlorinated well water with treated river water in the distribution system generates a more noticeable taste due to the different physical and chemical properties of the different waters. To ensure the safety of the water the same microbiological testing is completed weekly at various sites throughout the water distribution system, regardless of the water source.

The District received no water through its interties with the Cities of Redding and Shasta Lake during all of 2020.

Source water assessments were performed by the State Water Resources Control Board (State Board), Division of Drinking Water between January 2002 and April 2003. The District's Sacramento River source is considered most vulnerable to the following activities associated with contaminants detected in the water supply: (1) metal plating/finishing/ fabricating, (2) wood/pulp/paper processing and mills, and (3) drinking water treatment plants. The source is considered most vulnerable to the following activities not associated with any detected contaminants: (1) concentrated aquatic animal production facilities, (2) historic waste dumps/landfills, (3) landfills/dumps, (4) historic mining operations, and (5) wastewater treatment plants and disposal facilities (above Shasta Dam). The District's well sources are considered most vulnerable to the following activities not associated with any detected contaminants: (1) lumber processing and manufacturing; (2) septic systems - low density; (3) sewer collection systems; (4) historic waste dumps/landfills; (5) automobile - gas stations; and (6) utility stations - maintenance areas.

A copy of the complete assessment may be viewed at Bella Vista Water District, 11368 E. Stillwater Way, Redding, CA 96003. You may request a summary of the assessment be sent to you by contacting our office at info@bvwd.org or (530) 241-1085, ext. 105.

In 1989 the Federal Surface Water Treatment Rule set forth specific regulations requiring proper treatment of surface waters, as well as specific license requirements for water treatment operators. Although the regulations have changed dramatically, the overall process has not. Currently the District's staff includes 11 individuals with state certification as water treatment operators and 15 with certification as water distribution operators (including 12 individuals with certification as both) who contribute to the operation and maintenance of the District's facilities 365 days per year.

CONTAMINANTS IN WATER

The sources of drinking water (both tap water and bottled water) include rivers, lakes, streams, ponds, reservoirs, springs, and wells. As water travels over the surface of the land or through the ground, it dissolves naturally occurring minerals, and in some cases radioactive material and can pick up substances resulting from the presence of animals or from human activity. Contaminants that may be present in source water include:

- Microbial contaminants, such as viruses and bacteria that may come from sewage treatment plants, septic systems, agricultural livestock operations, and wildlife.
- Inorganic contaminants, such as salts and metals, that can be naturally-occurring or result from urban storm water runoff, industrial or domestic wastewater discharges, oil and gas production, mining, or farming.
- Pesticides and herbicides that may come from a variety of sources such as agriculture, urban storm water runoff, and residential uses.
- Organic chemical contaminants, including synthetic and volatile organic chemicals that are by-products of industrial processes and petroleum production, and can also come from gas stations, urban storm water runoff, agricultural application, and septic systems.

- Radioactive contaminants that can be naturally-occurring or be the result of oil and gas production and mining activities.

STATE AND FEDERAL REGULATIONS

In order to ensure that tap water is safe to drink, the U.S. Environmental Protection Agency (USEPA) and the State Water Resources Control Board (State Board) prescribe regulations that limit the amount of certain contaminants in water provided by public water systems. The U.S. Food and Drug Administration regulations and California law also establish limits for contaminants in bottled water that provide the same protection for public health. Additional information on bottled water is available on the California Department of Public Health website (<https://www.cdph.ca.gov/programs/CEH/DFDCS/Pages/FDBPrograms/FoodSafetyProgram/Water.aspx>).

The tables in this report list all of the drinking water contaminants that were detected during the most recent sampling for the constituent. The State Board allows us to monitor for certain contaminants less than once per year because the concentrations of these contaminants are not expected to vary significantly from year to year. Some of the data, though representative of our water quality, are more than one year old.

Drinking water, including bottled water, may reasonably be expected to contain at least small amounts of some contaminants. The presence of contaminants does not necessarily indicate that the water poses a health risk. More information about contaminants and potential health effects can be obtained by calling the USEPA's Safe Drinking Water Hotline at 1-800-426-4791.

A NOTE TO THE IMMUNO-COMPROMISED FROM THE UNITED STATES EPA

Some people may be more vulnerable to contaminants in drinking water than the general population. Immuno-compromised persons such as persons with cancer undergoing chemotherapy, persons who have undergone organ transplants, people with HIV/AIDS or other immune system disorders, some elderly and infants can be particularly at risk from infections. These people should seek advice about drinking water from their health care providers. USEPA/Center for Disease Control (CDC) guidelines on appropriate means to lessen the risk of infection by *Cryptosporidium* and other microbial contaminants are available from the Safe Drinking Water Hotline (1-800-426-4791).

REGARDING LEAD IN DRINKING WATER

If present, elevated levels of lead can cause serious health problems, especially for pregnant women and young children. Lead in drinking water is primarily from materials and components associated with service lines and home plumbing. Bella Vista Water District is responsible for providing high quality drinking water, but cannot control the variety of materials used in plumbing components. When your water has been sitting for several hours, you can minimize the potential for lead exposure by flushing your tap for 30 seconds to 2 minutes before using water for drinking or cooking. If you do so, you may wish to collect the flushed water and reuse it for another beneficial purpose, such as watering plants. If you are concerned about lead in your water, you may wish to have your water tested. Information on lead in drinking water, testing methods, and steps you can take to minimize exposure is available from the Safe Drinking Water Hotline or at <http://www.epa.gov/lead>.

ARSENIC IN THE DISTRICT'S WATER

H-3

Analysis of the District's surface and well waters has shown that it contains low levels of arsenic (less than 10 parts per billion). The arsenic standard balances the current understanding of arsenic's possible health effects against the costs of removing arsenic from drinking water. The U.S. Environmental Protection Agency continues to research the health effects of low levels of arsenic, which is a mineral known to cause cancer in humans at high concentrations and is linked to other health effects such as skin damage and circulatory problems.

ABOUT THE WATER QUALITY TABLES

Bella Vista Water District routinely monitors for constituents in your drinking water according to federal and state laws. The tables in this report show the results of our monitoring for the period through December 31, 2020. Where contaminants are monitored less than once per year, the values included in the report tables represent the results of the most recent analyses. In this table you will find many terms and abbreviations you might not be familiar with. To help you better understand these terms, the following definitions are provided:

Non-Detects (ND) - laboratory analysis indicates that the constituent is not detectable at current testing limits.

Parts per million (ppm) or Milligrams per liter (mg/L) - one part per million corresponds to one minute in 1.9 years or a single penny in \$10,000.

Parts per billion (ppb) or Micrograms per liter ($\mu\text{g/L}$) - one part per billion corresponds to one minute in 1,900 years, or a single penny in \$10,000,000.

Picocuries per liter (pCi/L) - picocuries per liter is a measure of the radioactivity in water.

Microsiemens per centimeter ($\mu\text{S/cm}$) is a unit for reporting the specific electrical conductance of the water.

Nephelometric Turbidity Unit (NTU) - nephelometric turbidity unit is a measure of the clarity of water. Turbidity (measured in NTU) is a measurement of the cloudiness of water and is a good indicator of water quality and filtration performance. Turbidity results which meet performance standards are considered to be in compliance with filtration requirements. Turbidity in excess of 5 NTU is just noticeable to the average person.

Maximum Contaminant Level (MCL) – The highest level of a contaminant that is allowed in drinking water. Primary MCLs are set as close to the PHGs (or MCLGs) as is economically and technologically feasible. Secondary MCLs are set to protect the odor, taste, and appearance of drinking water.

Maximum Contaminant Level Goal (MCLG) - The level of a contaminant in drinking water below which there is no known or expected risk to health. MCLGs are set by the U.S. Environmental Protection Agency (USEPA).

Maximum Residual Disinfectant Level (MRDL) - The highest level of a disinfectant allowed in drinking water. There is convincing evidence that addition of a disinfectant is necessary for control of microbial contaminants.

Maximum Residual Disinfectant Level Goal (MRDLG) - The level of a drinking water disinfectant below which there is no known or expected risk to health. MRDLGs do not reflect the benefits of the use of disinfectants to control microbial contaminants.

Public Health Goal (PHG) B The level of a contaminant in drinking water below which there is no known or expected risk to health. PHGs are set by the California Environmental Protection Agency.

Primary Drinking Water Standards (PDWS) - MCLs and MRDLs for contaminants that affect health along with their monitoring and reporting requirements, and water treatment requirements.

Regulatory Action Level (AL) - the concentration of a contaminant which, if exceeded, triggers treatment or other requirements that a water system must follow.

Treatment Technique (TT) - A required process intended to reduce the level of a contaminant in drinking water.

2020 RESULTS OF WATER QUALITY ANALYSES

Results of Sampling for Microbial Contamination					
Contaminant	MCL	Unit of Measurement	PHG (MCLG)	Highest Number of Detections	
				Treated Surface Water	Treated Well Water
1. Total Coliform Bacteria (Total Coliform Rule)	Presence of coliform bacteria in no more than one sample per month	presence/absence	0	None	None
2. Fecal coliform and <i>E.coli</i> (Total Coliform Rule)	A routine sample and repeat sample are total coliform positive, and one is also fecal coliform or <i>E. coli</i> positive	presence/absence	0	None	None
3. Fecal Indicators (<i>E.coli</i> , enterococci or coliphage) (Total Coliform Rule)	Treatment Technique	n/a	n/a	None	None

Note: BVWD analyzes a minimum of 5 water samples per week throughout the year in the water distribution system for coliform bacteria. A total of 260 coliform bacteria monitoring samples were taken during calendar year 2020.

2020 RESULTS OF WATER QUALITY ANALYSES (continued)

Sampling Results Showing Treatment of Surface Water Source (Sacramento River)					
Contaminant	Performance Standard / MCL (Treatment Technique)	Unit of Measurement	Level Found	Range	Violations
4. Turbidity	(1) Shall at no time exceed 1 NTU	Based on measurements made at 4 hour intervals while the plant is in operation	Less than 1.0 NTU at all times	0.020 NTU to 0.050 NTU	None
	(2) Less than 0.1 NTU in 95% of the measurements taken each month	Lowest Monthly % of measurements meeting the standard	100	100	None
	(3) Reduction in turbidity of 80% or more	Average monthly percentage reduction in turbidity	98.5	97.1 - 99.1	None
<i>Note: Turbidity is a measure of the cloudiness of the water. We monitor it because it is a good indicator of the effectiveness of our filtration system.</i>					

Sampling Results Showing the Detection of Contaminants with a Primary Drinking Water Standard							
Contaminant	MCL	PHG (MCLG)	Unit of Measurement	Sacramento River*		Well Water**	
				Average Value	Range	Average Value	Range
5. Gross Alpha	15	(0)	pCi/L	2.9	-	3	3
6. Radium 228	5	(0)	pCi/L	1.82	-	0.95	0.2 – 1.6
7. Aluminum	1000	0.6	ppb	226	-	ND	All ND
8. Arsenic	10	0.004	ppb	ND	-	4.07	2 – 8
9. Barium	1000	2	ppb	ND	-	155	ND - 297
10. Chromium, Total	50	(100)	ppb	ND	-	ND	All ND
11. Chromium, VI	***	0.02	ppb	ND	-	ND	ND
12. Fluoride	2.0	1	ppm	ND	-	0.048	ND - 0.14
Sacramento River and Well Water							
				2020 Highest Locational Running Annual Average		Range for Samples taken in 2020	
13. TTHM [Total trihalomethanes]****	80	N/A	ppb	41.0		0.0 – 41.5	
14. HAA5- [5 Haloacetic acids]****	60	N/A	ppb	37.0		0.0 – 35.9	
<i>Note: TTHM and HAA5 results are from samples collected from the Distribution System which may include water from both the river and wells.</i>							

* All results from the surface water source (which represents 91.5% of the water produced by the District in 2020) are from samples collected in 2020.

**Well water results reflect the latest results taken from each well; the results include samples collected over the period 2009 through 2020. The dates of the latest samples may be obtained by contacting the District's office.

*** There is currently no MCL for Chromium VI. The previous MCL of 10ppb was withdrawn on September 11, 2017.

**** The "Running Annual Average" includes samples collected in 2019 and 2020, while the Range includes the results of analysis of samples collected in 2020 only.

2020 RESULTS OF WATER QUALITY ANALYSES (continued)

Sampling Results Showing the Detection of Contaminants with a Secondary Drinking Water Standard							
(Aesthetic standards, established by the State Board - Division of Drinking Water)							
Contaminant or Analyte	MCL	PHG (MCLG)	Unit of Measure- ment	Sacramento River*		Well Water**	
				Average Level Detected	Range	Average Level Detected	Range
15. Foaming Agents (MBAS)	500	N/A	µg/L	ND	-	ND	ALL ND
16. Total dissolved solids	1,000	N/A	mg/L	76	-	198	149 - 243
17. Specific conductance	1,600	N/A	µS/cm	130	-	296	257-360
18. Chloride	500	N/A	mg/L	3.48	-	36	11 - 70
19. Sulfate	500	N/A	mg/L	3.12	-	2.2	0.8 – 4.9

Sampling Results for Unregulated Contaminants***							
(Unregulated contaminant monitoring helps the USEPA and the State Board to determine where certain contaminants occur and whether the contaminants need to be regulated.)							
Contaminant or Analyte	MCL	PHG (MCLG)	Unit of Measure- ment	Sacramento River*		Well Water**	
				Average Level Detected	Range	Average Level Detected	Range
20. Vanadium	Notification Level = 50 ppb	N/A	ppb	4.72		0.4	ND – 0.74

Sampling Results for Sodium, Hardness and pH							
Contaminant or Analyte	MCL	PHG (MCLG)	Unit of Measurement	Sacramento River*		Well Water**	
				Average Level Detected	Range	Average Level Detected	Range
21. Sodium	N/A	N/A	ppm	6.1	-	43	25 - 66
22. Hardness	N/A	N/A	ppm	48	-	63	45 - 87
23. pH	6.5 - 8.5	N/A	pH units	7.71	-	7.95	7.8 – 8.1

* All results from the surface water source (which represents 91.5% of the water produced by the District in 2020) are from samples collected in 2020.

**Well water results reflect the latest results taken from each well; the results include samples collected over the period 2010 through 2020. The dates of the latest samples may be obtained by contacting the District's office.

***In 2013 and 2014 the District sampled for a number of additional unregulated contaminants in the water. The results of these samples were either non-detectable or below notification levels. Additional information regarding unregulated contaminants is available by contacting the District's office.

2020 RESULTS OF WATER QUALITY ANALYSES (continued)

Sampling Results Showing the Detection of Lead and Copper						
Contaminant	PHG (MCLG)	Action Level (AL)	90 th percentile level detected	No. of samples collected	No. of Sites exceeding Action Level	Typical Source of Contaminant
Lead (ppb)	0.2	15	ND	30	0	Internal corrosion of household water plumbing systems; discharges from industrial manufacturers; erosion of natural deposits
Copper (ppm)	0.3	1.3	0.250	30	0	Internal corrosion of household water plumbing systems; erosion of natural deposits; leaching from wood preservatives
<i>Note: The District is required to conduct lead and copper sampling every three years. These results are from the most recent round of sampling from July 2019. The next round of sampling is scheduled for July of 2022. No schools requested lead sampling in 2020.</i>						

Disinfectant Residuals found in the Distribution System during 2019						
Contaminant	MCL [MRDL]	PHG (MRDLG)	Average Value	Range	Major Sources in Drinking Water	Health Effects
Chlorine (ppm)	4.0 (as Cl ₂)	4	0.84	0.13 to 1.40	Drinking water disinfectant added for treatment	Some people who use water containing chlorine well in excess of the MRDL could experience irritating effects to their eyes and nose. Some people who drink water containing chlorine well in excess of the MRDL could experience stomach discomfort.

MRDL = Maximum Residual Disinfectant Level (The highest level of a disinfectant allowed in drinking water. There is convincing evidence that addition of a disinfectant is necessary for the control of microbial contaminants.)

MRDLG = The level of a drinking water disinfectant below which there is no known or expected risk to health. MRDLGs do not reflect the benefits of the use of disinfectants to control microbial contaminants.

TYPICAL SOURCES OF DETECTED CONTAMINANTS

Contaminant	Typical Source of Contaminant
1. Total Coliform Bacteria	Naturally present in the environment
2. Fecal Coliform and <i>E. coli</i>	Human and animal fecal waste
3. Fecal	Human and animal fecal waste
4. Turbidity	Soil runoff
5. Gross Alpha	Erosion of natural deposits
6. Radium 228	Erosion of natural deposits
7. Aluminum	Erosion of natural deposits; residue from some surface water treatment
8. Arsenic	Erosion of natural deposits; runoff from orchards; glass and electronics production wastes
9. Barium	Discharge of oil drilling wastes and from metal refineries; erosion of natural deposits
10. Chromium	Discharge from steel and pulp mills and chrome plating; erosion of natural deposits
11. Fluoride	Erosion of natural deposits; water additive which promotes strong teeth; discharge from fertilizer and aluminum factories
12. TTHM [Total trihalomethanes]	By-products of drinking water chlorination
13. Haloacetic Acids	By-products of drinking water chlorination
14. Foaming Agents (MBAS)	Municipal and industrial waste discharges
15. Total dissolved solids	Runoff/ leaching from natural deposits
16. Specific conductance	Substances that form ions when in water; seawater influence
17. Chloride	Runoff/leaching from natural deposits; seawater influence
18. Sulfate	Runoff/leaching from natural deposits; seawater influence
19. Vanadium	Natural sources and from the burning of fuel oils
20. Hexavalent Chromium	Discharge from electroplating factories, leather tanneries, wood preservation, chemical synthesis, refractory production, and textile manufacturing facilities; erosion of natural deposits

OTHER TEST RESULTS OF INTEREST

Constituent	Description and Source Information
21. Sodium	Refers to the salt present in the water and is generally naturally-occurring
22. Hardness	Is the sum of polyvalent cations present in the water, generally magnesium and calcium. These cations are generally naturally-occurring.
23. pH	The pH of a water is a measure of its hydrogen ion activity or acidity. By definition the pH of pure water is 7.0. The pH range of most natural waters is about 6.0 to 8.5.

YOUR VIEWS ARE WELCOME

If you have any questions about this report, please contact Tom Zaharris, District Treatment Superintendent, at (530) 241-1085, ext. 201. We want our valued customers to be informed about their water district. If you want to learn more, please visit the District's web site: www.bvwd.org or attend any of our regularly scheduled Board of Directors meetings. The meetings are typically held on the fourth Monday of each month at 5:30 p.m. at the District office, located at 11368 E. Stillwater Way, Redding, CA 96003. Agendas are posted on the District's website.